

BIRATIONAL CONTRACTIONS OF $\overline{M}_{0,n}$ AND COMBINATORICS OF EXTREMAL ASSIGNMENTS

HAN-BOM MOON, CHARLES SUMMERS, JAMES VON ALBADE, AND RANZE XIE

ABSTRACT. From Smyth's classification, modular compactifications of the moduli space of pointed smooth rational curves are indexed by combinatorial data, so-called extremal assignments. We explore their combinatorial structures and show that any extremal assignment is a finite union of atomic extremal assignments. We discuss a connection with the birational geometry of the moduli space of stable pointed rational curves. As applications, we study three special classes of extremal assignments: smooth, toric, and invariant with respect to the symmetric group action. We identify them with three combinatorial objects: simple intersecting families, complete multipartite graphs, and special families of integer partitions, respectively.

1. INTRODUCTION

A fascinating fact about the moduli space $\overline{M}_{0,n}$ of stable n -pointed rational curves is that it has rich combinatorial structures. There is a natural stratification indexed by the set of stable n -labeled trees, or matroid polytope decompositions ([Kap93a]). The closure of each stratum is isomorphic to a product of $\overline{M}_{0,n}$'s with a small number of marked points, and the universal family over $\overline{M}_{0,n}$ is isomorphic to $\overline{M}_{0,n+1}$, so there are two inductive structures. The limit computation on $\overline{M}_{0,n}$ can be explained in terms of Bruhat-Tits building ([Kap93b]). A natural connection with root systems of type A was also observed ([Sek96]).

Recently Smyth found yet another example of an interplay between geometry on $\overline{M}_{0,n}$ and combinatorics. In [Smy13], he gave a classification of modular compactifications of the moduli space $M_{0,n}$ of smooth rational curves with n distinct points in the algebraic stack of all pointed curves. He showed that these compactifications can be indexed by combinatorial data, so-called *extremal assignments*. An extremal assignment Z is a collection of subsets $Z(G) \subset V(G)$ for every stable n -labeled tree G , with two conditions (Definition 3.1):

- (1) $Z(G) \neq V(G)$;
- (2) For any contraction $G \rightsquigarrow G'$ which contracts $\{v_1, v_2, \dots, v_k\} \subset V(G)$ to $v' \in V(G')$, $v_1, v_2, \dots, v_k \in Z(G)$ if and only if $v' \in Z(G')$.

For each extremal assignment Z , Smyth constructed a moduli space $\overline{M}_{0,n}(Z)$ of n -pointed rational curves with certain singularities, in the category of algebraic spaces. It is shown that there is a dominant regular map $\overline{M}_{0,n} \rightarrow \overline{M}_{0,n}(Z)$ which preserves $M_{0,n}$ (Proposition 3.9). Thus $\overline{M}_{0,n}(Z)$ is a *birational contraction* of $\overline{M}_{0,n}$.

The aim of this paper is to study the combinatorics of extremal assignments and to translate the result in terms of birational contractions of $\overline{M}_{0,n}$.

1.1. Structure theorem of extremal assignments. Although the definition of an extremal assignment is simple and natural, answering the following natural questions is surprisingly subtle.

Question 1.1. Let G_1, G_2, \dots, G_k be stable n -labeled trees and let $v_1 \in V(G_1), v_2 \in V(G_2), \dots, v_k \in V(G_k)$.

- (1) Is there an extremal assignment Z such that $v_i \in Z(G_i)$?
- (2) Describe the smallest Z such that $v_i \in Z(G_i)$. Or equivalently, for any G and any $v \in V(G)$, determine whether v must be assigned or not.

To answer these questions, first we prove a structure theorem of extremal assignments. An *atomic* extremal assignment is the smallest extremal assignment with an assigned vertex. We will explain relevant notations (mainly for the partial ordering of set partitions) in the statement below in Section 6.

Theorem 1.2. (1) (Proposition 6.5) *There is a one-to-one correspondence between the set of atomic extremal assignments and the set of set partitions P of $[n]$ with $3 \leq |P| \leq n - 1$.*
 (2) (Lemma 6.7) *Any extremal assignment Z of order n is a union of finitely many atomic extremal assignments.*
 (3) (Proposition 6.9 and Theorem 6.10) *For atomic extremal assignments Z_1, Z_2, \dots, Z_k and the corresponding set partitions P_1, P_2, \dots, P_k , the union $Z := \bigcup_{i=1}^k Z_i$ is an extremal assignment if and only if for any two $Q_1 \preceq P_i$ and $Q_2 \preceq P_j$ with the tight upper bound R , there is P_ℓ such that $R \leq P_\ell$.*

Based on Theorem 1.2, we provide an algorithm and its implementation for finding the smallest Z in Question 1.1.

1.2. Smooth models and simple intersecting families. As applications of the structure theorem, we explore three special cases of extremal assignments and their associated birational models.

The first natural class is the collection of smooth models. We give a characterization of extremal assignments that provide smooth models. A *smooth extremal assignment* is an extremal assignment Z such that for any G and $v \in Z(G)$, there is G' with two vertices and $v' \in Z(G')$ such that $G \rightsquigarrow G'$ and $v \rightsquigarrow v'$.

Theorem 1.3. (1) (Theorem 7.8) *An extremal assignment Z provides a smooth birational contraction $\overline{M}_{0,n}(Z)$ if and only if Z is equivalent to a smooth extremal assignment.*
 (2) (Theorem 7.10) *There is a one-to-one correspondence between the set of smooth extremal assignments of order n and the set of simple intersecting families of order n , rank $\leq n - 2$, and antirank ≥ 2 .*

A simple intersecting family is a special class of hypergraphs ([Ber89, Section 1.3]) such that any two hyperedges properly intersect.

1.3. Toric models and complete multipartite graphs. The next class of examples is toric models. The Losev-Manin space $\overline{M}_{0,n}^{LM}$ ([LM00]) is the closest toric variety to $\overline{M}_{0,n}$ among Hassett's moduli

spaces $\overline{M}_{0,A}$ of weighted stable curves ([Has03]). $\overline{M}_{0,n}^{LM}$ is constructed as an iterated toric blow-up of \mathbb{P}^{n-3} . Thus if we take an intermediate space of this construction, it gives a toric birational model of $\overline{M}_{0,n}$. For any connected graph G of order $n - 2$, one can associate a polytope PG , a so-called *graph associahedron*, and its corresponding toric variety $X(PG)$ is one of the intermediate spaces. In [dRJR16], the authors found a characterization of G where $X(PG)$ is indeed one of Hassett's moduli spaces of weighted stable curves, and asked when $X(PG)$ is indeed isomorphic to a modular birational model of $\overline{M}_{0,n}$ ([dRJR16, Remark 12]). Here we answer the question.

Theorem 1.4 (Theorem 8.5). *For any connected graph G of order $n - 2$, $X(PG)$ is $\overline{M}_{0,n}(Z)$ for some extremal assignment Z if and only if G is a complete multipartite graph.*

Therefore for almost every graph G , $X(PG)$ is not modular. This implies that for the study of contractions of $\overline{M}_{0,n}$, studying modular compactifications from extremal assignments is insufficient.

1.4. S_n -invariant models and integer partitions. We study S_n -invariant extremal assignments. The natural S_n -action permuting n labels induces the S_n -action on $\overline{M}_{0,n}$ and the set of extremal assignments of order n . For an S_n -invariant extremal assignment Z , on $\overline{M}_{0,n}(Z)$, S_n acts too, and the contraction $\overline{M}_{0,n} \rightarrow \overline{M}_{0,n}(Z)$ is S_n -equivariant. Thus an S_n -invariant extremal assignment Z provides a contraction $\tilde{M}_{0,n} := \overline{M}_{0,n}/S_n \rightarrow \overline{M}_{0,n}(Z)/S_n$.

We prove the following analogue of the structure theorem of ordinary extremal assignments. As one may expect, the theorem can be described in terms of integer partitions, rather than set partitions. However, the result is not a simple restatement, because if we forget labels, then there are nontrivial automorphisms of the underlying graphs even for trees. For the definition of the special family of integer partitions, see Definition 9.3.

Theorem 1.5 (Theorem 9.5). *There is a one-to-one correspondence between the set of S_n -invariant extremal assignments and the set of special families of integer partitions.*

In summary, in these three special cases, one may translate a question about extremal assignments or modular contractions of $\overline{M}_{0,n}$ into the terms of simpler combinatorial objects. We may summarize the situation as Figure 1.

1.5. Computer programs. Based on Theorem 1.2 (resp. Theorem 1.5), we are able to describe an algorithm for finding the smallest extremal assignment Z in Question 1.1. We implemented this algorithm as a program in Sage ([S⁺]). It can be found on the website of the first author:

<http://www.hanbommoon.net/publications/extremal>

1.6. Classification of contractions and projectivity question. In the moduli-theoretic viewpoint, there are two known families of birational contractions of $\overline{M}_{0,n}$. One is obtained from extremal assignments, as we discussed above. The other family, the so-called family of *Veronese quotients*, is obtained from geometric invariant theory (GIT) ([GJM13, GJMS13]). Constructions of birational contractions in these two viewpoints are very general and exhaustive in some sense, so one may wonder whether all of the projective birational contractions (in the sense of Mori's program or the log minimal model program) of $\overline{M}_{0,n}$ are essentially obtained from these two families.

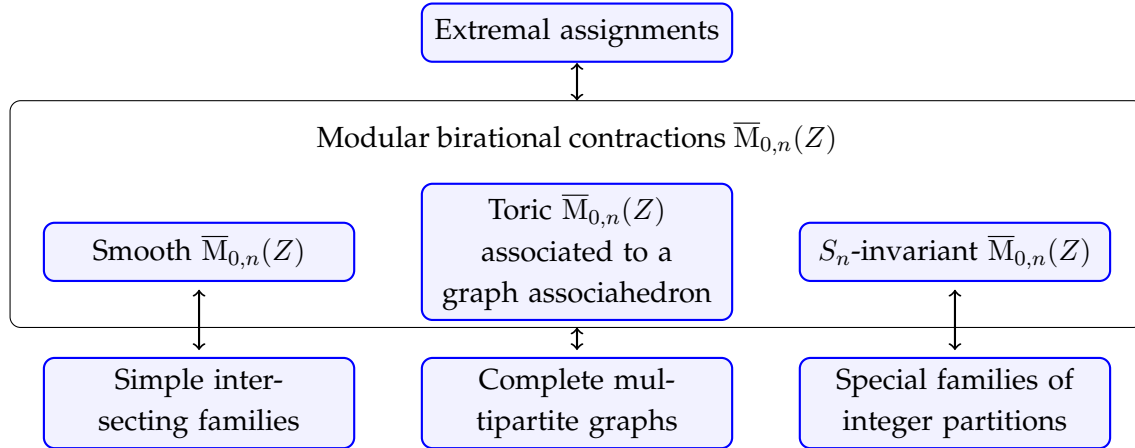

FIGURE 1. Three correspondences of combinatorial objects

The structure of the nef cone of $\overline{M}_{0,n}$ is generally open for $n \geq 8$, and it is complicated even for small n . Thus we focused on the S_n -invariant nef cone of $\overline{M}_{0,n}$, or, equivalently, the nef cone of $\widetilde{M}_{0,n} := \overline{M}_{0,n}/S_n$. In Section 10, we show that for $n \leq 8$, all birational models are obtained from extremal assignments and Veronese quotients, but from $n = 9$, some contractions do not come from these two families.

One interesting result is the following. A priori, the modular contractions $\overline{M}_{0,n}(Z)$ from extremal assignments exist in the category of algebraic spaces. However, some of them are not projective varieties. We give three explicit examples of non-projective contractions. Indeed, two of them are smooth proper non-projective varieties. Thus, by using extremal assignments, we are able to construct many examples of smooth, non-projective proper algebraic varieties. Finally, for smooth extremal assignments, we give a partial criterion for the projectivity (Corollary 7.13, Proposition 7.15), and show that the associated birational contractions are always varieties (Proposition 11.5).

1.7. Further works. There have been many results ([Man95, Cey09, Moo11, BH11, BM13, BM14]) on the computation of motivic invariants of $\overline{M}_{0,n}$, and more generally, for $\overline{M}_{0,A}$. For instance, their Poincaré polynomials were computed in some special cases ([Moo11, BM13, BM14]). It would be great if one could find a concise closed or iterative formula describing the Poincaré polynomial for arbitrary weight data. However, it appears that the weight data are not appropriate input data for such a formula, as many different weights give the same space. We expect that the formula may be extracted from the associated smooth extremal assignment, since it determines the moduli space uniquely. We will explore this motivic computation in a forthcoming paper.

1.8. Structure of the paper. This paper is organized in the following format. In Section 2, we review the definition and basic properties of $\overline{M}_{0,n}$, its subvarieties, and dual graphs. We recall the definition of an extremal assignment and its functorial properties in Section 3. Section 4 gives some important classes of examples. In Section 5, we give a complete list of equivalence classes of extremal assignments for $n = 5$, as a warm-up. Section 6 is devoted to the proof of the structure

theorem (Theorem 6.10). In the next several sections, we give applications of this structure theorem. In Section 7, we give a characterization of extremal assignments giving smooth birational contractions. In Section 8, we study toric birational models. S_n -invariant extremal assignments are discussed in Section 9. By applying this theory, we compute the birational contractions associated to the nef cone of $\widetilde{M}_{0,n}$ for small n in Section 10. Finally, we give examples of non-projective models in the last section.

Notation.

- Let $[n] := \{1, 2, \dots, n\}$. A k -subset of $[n]$ is $S \subset [n]$ such that $|S| = k$.
- A *labeled graph* is a graph G with a bijective map between the set of end vertices and a given label set. Usually we use $[n]$ as a label set.
- For any labeled graph G , $V(G)$ is the set of internal (thus non-labeled) vertices.
- An n -labeled tree G is called a *star* if every internal vertex is connected to a single vertex v . v is called a *central vertex*.
- $S(n)$ is the set of all stable n -labeled trees. When we use a specific label set X instead of $[n]$, we use $S(X)$.
- $\mathcal{P}(n)$ is the set of set partitions of $[n]$.
- A *tail* T of a graph (or labeled graph) G is a connected subgraph of G such that there is only one vertex $v \in T$ which is adjacent to T^c .
- For a subgraph T , the label set $\ell(T)$ is the set of all labels adjacent to T . $\ell(v) = \ell(\{v\})$.
- We denote an n -dimensional weight vector (a, a, \dots, a) by a^n . (a, a, \dots, a, b) is denoted by (a^{n-1}, b) , and so on.

Acknowledgements. The first author would like to thank Andreas Blass, Daniel Soltész, and David Swinarski. The authors would like to thank anonymous referees for careful reading and many suggestions. The first, second, and third authors were partially supported by the Fordham University Summer Undergraduate Research Program.

2. PRELIMINARIES

2.1. The moduli space $\overline{M}_{0,n}$. In this section, we summarize the definition and basic facts of the moduli space $\overline{M}_{0,n}$ of stable n -pointed rational curves.

Definition 2.1. A *stable n -pointed rational curve* is a complex n -pointed curve $(C, x_1, x_2, \dots, x_n)$ such that

- (1) C is a connected, projective curve of arithmetic genus 0 with at worst nodal singularities;
- (2) x_i 's are distinct smooth points on C ;
- (3) Every irreducible component of C has at least 3 special points (singular points or marked points).

Let $\overline{M}_{0,n}$ be the moduli space of stable n -pointed rational curves.

The space $\overline{M}_{0,n}$ is a fine moduli space and it is a smooth projective variety of dimension $n - 3$. If we want to use a specific index set S instead of $[n]$, we denote by $\overline{M}_{0,S}$.

By considering loci of singular curves with fixed topological types, we can obtain subvarieties that define a stratification structure on $\overline{\mathcal{M}}_{0,n}$.

Definition 2.2. For any $I \subset [n]$ with $2 \leq |I| \leq n - 2$, let D_I be the closure of the locus of curves $(C = C_1 \cup C_2, x_1, x_2, \dots, x_n)$ with two irreducible components C_1 and C_2 such that $x_i \in C_1$ if and only if $i \in I$. By definition, $D_I = D_{I^c}$. D_I is called a *boundary divisor*. Let $D = \bigcup_I D_I$ and $D_i = \bigcup_{|I|=i} D_I$.

Each D_I is a divisor of $\overline{\mathcal{M}}_{0,n}$, and it is isomorphic to $\overline{\mathcal{M}}_{0,I \cup \{p\}} \times \overline{\mathcal{M}}_{0,I^c \cup \{q\}}$. The total boundary divisor D is a simple normal crossing divisor. Thus, by taking a nonempty intersection of its irreducible components, we obtain a subvariety with the expected codimension. The intersection $D_{I_1} \cap D_{I_2} \cap \dots \cap D_{I_r}$ is nonempty if and only if for any two distinct indices i and j , $I_i \subset I_j$ or $I_i \cap I_j = \emptyset$. The stratification on $\overline{\mathcal{M}}_{0,n}$ obtained by these nonempty intersections of boundary divisors is called the *boundary stratification*.

Definition 2.3. Let $I_1 \sqcup I_2 \sqcup I_3 \sqcup I_4 = [n]$ be a set partition. For each i , we define a ‘tail’ C_i as the following. If $|I_i| > 1$, we define C_i as the \mathbb{P}^1 with $|I_i| + 1$ distinct fixed points with labels $I_i \cup \{p_i\}$. If $|I_i| = 1$, $C_i = \{p_i\}$ is a point. Construct $(C, x_1, x_2, \dots, x_n) \in \overline{\mathcal{M}}_{0,n}$ by gluing four fixed tails C_i to a four pointed curve $(\mathbb{P}^1, q_1, q_2, q_3, q_4)$ along p_i and q_i . An *F-curve* $F_{I_1, I_2, I_3, I_4} \subset \overline{\mathcal{M}}_{0,n}$ is obtained by varying the cross ratio of q_j ’s. On $\widetilde{\mathcal{M}}_{0,n} := \overline{\mathcal{M}}_{0,n}/S_n$, we define an F-curve F_{i_1, i_2, i_3, i_4} as any F-curve F_{I_1, I_2, I_3, I_4} so that $|I_j| = i_j$.

An F-curve F_{I_1, I_2, I_3, I_4} is numerically equivalent to any 1-dimensional nonempty intersection of boundaries

$$\left(\bigcap_{|I_i| > 1} D_{I_i} \right) \cap D_{J_1} \cap D_{J_2} \cap \dots$$

The intersection number of a boundary divisor and an F-curve is given by the following lemma.

Lemma 2.4. [KM13, Lemma 4.3].

$$F_{I_1, I_2, I_3, I_4} \cdot D_J = \begin{cases} 1, & J = I_i \cup I_j \text{ for two } i, j, \\ -1, & J = I_i, \\ 0, & \text{otherwise.} \end{cases}$$

Boundary divisors generate $N^1(\overline{\mathcal{M}}_{0,n})$, and F-curves generate $N_1(\overline{\mathcal{M}}_{0,n})$.

2.2. Graph theoretic notation. The boundary stratification of $\overline{\mathcal{M}}_{0,n}$ can be described in terms of stable labeled trees. In this section, we briefly review their combinatorics.

Definition 2.5. A *stable n -labeled tree* is a finite graph with n leaves $\{1, 2, \dots, n\}$ satisfying:

- (1) The underlying graph is a tree (i.e., there is no circuit).
- (2) Every (internal) vertex has at least 3 adjacent edges.

Let $S(n)$ be the set of all stable n -labeled trees. Let $S_k(n) \subset S(n)$ be the subset of stable n -labeled trees with precisely k internal vertices. It is straightforward to check that

$$S(n) = \bigcup_{k=1}^{n-2} S_k(n).$$

If there is no further explanation, a vertex of a labeled tree is always an internal vertex.

We can impose a natural partially ordered set structure on $S(n)$.

Definition 2.6. For $G, G' \in S(n)$, we say G' is a *contraction* of G (denoted by $G \rightsquigarrow G'$) if we can make G' from G by repeating the following collapsing operation: Replace a nonempty connected subgraph by a vertex. For a contraction $\pi : G \rightsquigarrow G'$ and $v' \in V(G')$, by abuse of notation we denote $V(G) \rightarrow V(G')$ by π . If $\{v_1, v_2, \dots, v_k\} = \pi^{-1}(v')$, we write $\{v_1, v_2, \dots, v_k\} \rightsquigarrow v$.

Let $G \leq G'$ if $G \rightsquigarrow G'$. Then $S(n)$ is a partially ordered set.

Example 2.7. Figure 2 shows two stable 6-labeled trees such that $G \rightsquigarrow G'$ and $\{v_0, v_1\} \rightsquigarrow v'$.

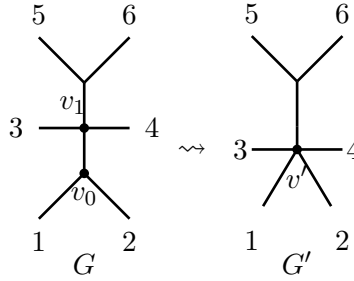

FIGURE 2. An example of contraction

Definition 2.8. For $X := (C, x_1, x_2, \dots, x_n) \in \overline{M}_{0,n}$, the *dual graph* G is a stable n -labeled tree constructed as the following. The set $V(G)$ of vertices is the set of irreducible components of C . Two vertices v, w are connected if two corresponding irreducible components meet. We put a label i on a vertex v if x_i lies on the corresponding irreducible component. The condition (3) of Definition 2.1 implies the stability of G .

Example 2.9. Figure 3 shows a curve in $\overline{M}_{0,6}$ and its dual graph.

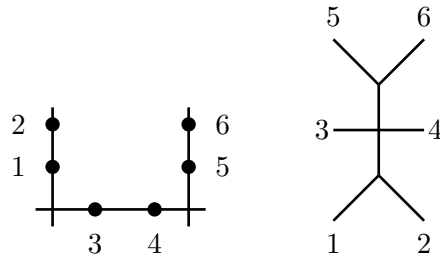

FIGURE 3. A stable 6-pointed rational curve and its dual graph

Example 2.10. Suppose that G is a tree with two vertices, and the set of labels on a vertex is $I \subset [n]$. Then the corresponding curve $X = (C_1, x_1, x_2, \dots, x_n)$ is on D_I .

For $G \in S(n)$, let $D_G \subset \overline{M}_{0,n}$ be the locus of curves whose dual graph is G . Then D_G is a smooth locally-closed subvariety of $\overline{M}_{0,n}$ that is an intersection of several boundary divisors. Also $G \leq G'$ if and only if $D_G \subset \overline{D_{G'}}$.

3. EXTREMAL ASSIGNMENTS AND BIRATIONAL CONTRACTIONS OF $\overline{M}_{0,n}$

In [Smy13], Smyth introduced a combinatorial object, a so-called extremal assignment, which defines a contraction of $\overline{M}_{0,n}$. In this section, we give its definition and basic properties.

Definition 3.1. (1) An *assignment* \overline{Z} on $T \subset S(n)$ is a rule assigning for each $G \in T$ a subset $\overline{Z}(G) \subset V(G)$.

(2) An assignment Z on $S(n)$ is called an *extremal assignment of order n* if:

(a) $Z(G) \neq V(G)$ for any $G \in S(n)$;

(b) If $G \rightsquigarrow G'$ and $\{v_1, v_2, \dots, v_k\} \rightsquigarrow v'$, then $v' \in Z(G') \Leftrightarrow v_1, v_2, \dots, v_k \in Z(G)$.

Remark 3.2. In [Smy13, Definition 1.5], Smyth defines an extremal assignment for arbitrary genus g graphs. It is straightforward to see that his condition (2) is trivial for the $g = 0$ case, because any stable n -labeled tree has a trivial automorphism group.

We define several natural operations.

Definition 3.3. An extremal assignment Z' is called a *sub extremal assignment* of Z if $Z'(G) \subset Z(G)$ for every $G \in S(n)$. We denote by $Z' \subset Z$.

Definition 3.4. Let Z_1, \dots, Z_k be extremal assignments. The *intersection* $Z := \bigcap_{i=1}^k Z_i$ is defined by $Z(G) := \bigcap_{i=1}^k Z_i(G)$. Z is also an extremal assignment.

However, in general the *union* $Z := \bigcup_{i=1}^k Z_i$, which is defined by $Z(G) = \bigcup_{i=1}^k Z_i(G)$, is *not* an extremal assignment.

Example 3.5. Let $G \in S_2(n)$ have two vertices, v_1 and v_2 . Let Z_1 and Z_2 be two extremal assignments with $v_1 \in Z_1(G)$ and $v_2 \in Z_2(G)$. Then $Z_1 \cup Z_2$ is not an extremal assignment, since $Z(G) = V(G)$.

For a classification of modular compactifications of $M_{0,n}$, extremal assignments have a central role. A *modular compactification* of $M_{0,n}$ is a compactification that can be interpreted as a moduli space of a certain type of pointed curves. More precisely, it is defined as a proper open substack \mathcal{M} of the stack of all n -pointed genus 0 curves containing $M_{0,n}$.

By using an extremal assignment Z , we can define a modular compactification $\overline{M}_{0,n}(Z)$ as follows. Since there is a one-to-one correspondence between the set of irreducible components on $(C, x_1, \dots, x_n) \in \overline{M}_{0,n}$ and $V(G)$ for its dual graph G , $Z(G)$ defines a subset of irreducible components of C . We will denote the subset by $Z(C)$.

Definition 3.6 ([Smy13, Definition 1.8]). Let Z be an extremal assignment. An n -pointed curve $(C, x_1, x_2, \dots, x_n)$ of arithmetic genus 0 is Z -stable if there exists $(C^s, x_1^s, \dots, x_n^s) \in \overline{M}_{0,n}$ and a map $\phi : (C^s, x_1^s, \dots, x_n^s) \rightarrow (C, x_1, \dots, x_n)$ satisfying

- (1) ϕ is surjective with connected fibers;
- (2) $\phi|_{C^s - Z(C^s)}$ is an isomorphism;
- (3) For a connected component Z' of $Z(C^s)$, $\phi(Z')$ is a single point.

We can naturally define the notion of flat families of Z -stable curves. Let $\overline{M}_{0,n}(Z)$ be the moduli stack of Z -stable curves.

Theorem 3.7 ([Smy13, Theorem 1.9, Theorem 1.21]). Let Z be an extremal assignment. Then $\overline{M}_{0,n}(Z)$ is a modular compactification of $M_{0,n}$. Conversely, for any modular compactification \mathcal{M} of $M_{0,n}$, there exists an extremal assignment Z such that $\mathcal{M} \cong \overline{M}_{0,n}(Z)$. The compactification $\overline{M}_{0,n}(Z)$ exists in the category of algebraic spaces.

Remark 3.8. Smyth proved a more general result for arbitrary genus g . In the case of genus 0, which will be discussed in this paper, we have the following result as well.

Proposition 3.9. (1) For any extremal assignment Z , there is a birational contraction $\pi_Z : \overline{M}_{0,n} \rightarrow \overline{M}_{0,n}(Z)$ which has connected fibers.

- (2) More generally, if $Z_1 \subset Z_2$, there is a birational map $\pi_{Z_1, Z_2} : \overline{M}_{0,n}(Z_1) \rightarrow \overline{M}_{0,n}(Z_2)$. Furthermore, for any three extremal assignments $Z_1 \subset Z_2 \subset Z_3$, there is a commutative diagram

$$\begin{array}{ccc}
 \overline{M}_{0,n}(Z_1) & \xrightarrow{\pi_{Z_1, Z_3}} & \overline{M}_{0,n}(Z_3) \\
 & \searrow \pi_{Z_1, Z_2} & \nearrow \pi_{Z_2, Z_3} \\
 & & \overline{M}_{0,n}(Z_2)
 \end{array}$$

Proof. For any family $(\rho : \mathcal{C} \rightarrow S, \sigma_1, \dots, \sigma_n : S \rightarrow \mathcal{C})$ of stable n -pointed rational curves, by contracting irreducible components assigned by the data Z , we obtain a family of Z -stable curves $\mathcal{C}' \rightarrow S$. At the image of a contracted component, a fiber of \mathcal{C}' has a singularity of arithmetic genus zero. From the classification of arithmetic genus zero singularities ([Smy13, Lemma 1.17]), it is a multinodal singularity, which is locally the union of coordinate axes in \mathbb{C}^k . In particular, there is no nontrivial moduli for this singularity. Therefore, the contracted curve is defined uniquely, so we have a well-defined map $\pi_Z : \overline{M}_{0,n} \rightarrow \overline{M}_{0,n}(Z)$. This proves (1).

If $Z_1 \subset Z_2$, it is straightforward to check that for any $x \in \overline{M}_{0,n}(Z_1)$, the fiber $\pi_{Z_1}^{-1}(x) \subset \overline{M}_{0,n}$ is contracted to a single point in $\overline{M}_{0,n}(Z_2)$ by π_{Z_2} . By the rigidity lemma, the map π_{Z_2} factors through $\overline{M}_{0,n}(Z_1)$. We will denote this map by π_{Z_1, Z_2} . The commutativity is clear from their set theoretic descriptions. \square

The contracted locus of the reduction map π_{Z_1, Z_2} can be described in terms of restricted extremal assignments.

Definition 3.10. Fix an extremal assignment Z . Let $G \in S(n)$ and let $v \in V(G) \setminus Z(G)$. Recall that $\ell(v)$ is the set of labels adjacent to v . Let E_v be the set of edges adjacent to v . With new label set $\ell(v) \cup E_v$, we can define the *restriction* $Z|_v$ of Z as the following. For any $H \in S(\ell(v) \cup E_v)$, there

is a contraction $\pi : G' \rightsquigarrow G$ such that G' is obtained from G by replacing v and adjacent edges by H . Then for $w \in V(H)$, set $w \in Z|_v(H) \Leftrightarrow w \in Z(G')$. See Figure 4. If $G \in S_2(n)$ with two vertices v, w and the label set for v (resp. w) is B (resp. B^c), then we write $Z^B := Z|_v$ (resp. $Z^{B^c} := Z|_w$).

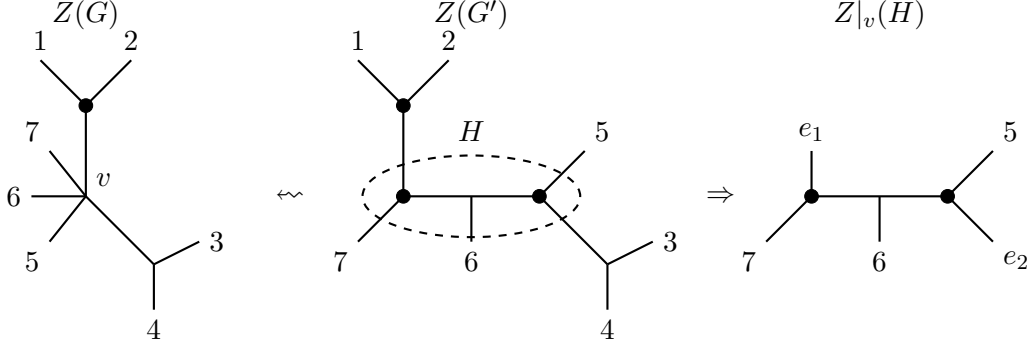

FIGURE 4. The restriction of an extremal assignment. The dotted vertices are assigned.

Remark 3.11. For a graph $G \in S(n)$, recall that $D_G \subset \overline{\mathcal{M}}_{0,n}$ is the locus of curves whose dual graph is G . We denote its image on $\overline{\mathcal{M}}_{0,n}(Z_1)$ with the same notation. Then

$$\overline{D}_G \cong \prod_{v \in V(G) \setminus Z_1(G)} \overline{\mathcal{M}}_{0,|\ell(v) \cup E_v|}(Z_1|_v).$$

The image $\pi_{Z_1, Z_2}(\overline{D}_G)$ is obtained by forgetting newly assigned components. More precisely,

$$\pi_{Z_1, Z_2}(\overline{D}_G) \cong \prod_{v \in V(G) \setminus Z_2(G)} \overline{\mathcal{M}}_{0,|\ell(v) \cup E_v|}(Z_2|_v).$$

Example 3.12. Let Z be an extremal assignment that assigns $v \in V(G)$ for the dual graph G in Figure 5. Let $(C, x_1, x_2, \dots, x_6) \in \overline{\mathcal{M}}_{0,n}$ be a stable 6-pointed curve whose dual graph is G . Then the central component is assigned, thus the contraction $(C', x'_1, x'_2, \dots, x'_6)$ is a Z -stable curve. See Figure 5. In general, two or more marked points may collide, and some marked points may lie on a singular point. If an assigned vertex has three or more adjacent internal vertices, then the contracted curve has a multinodal singularity.

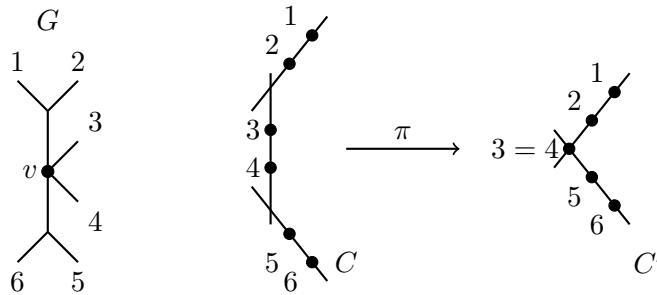

FIGURE 5. An example of contraction map

Sometimes for two extremal assignments Z_1, Z_2 , the corresponding contractions $\overline{\mathcal{M}}_{0,n}(Z_1)$ and $\overline{\mathcal{M}}_{0,n}(Z_2)$ are bijective. We would like to identify these cases.

Definition 3.13. Let $G \in S(n)$ and $W(G) \subset V(G)$. A vertex $v \in W(G)$ is called *isolated* if none of the vertices adjacent to v is in $W(G)$.

Definition 3.14. We say two extremal assignments Z_1 and Z_2 of order n are *equivalent* (denoted by $Z_1 \sim Z_2$) if for any $G \in S(n)$, both $Z_1(G) \setminus Z_2(G)$ and $Z_2(G) \setminus Z_1(G)$ are unions of isolated 3-valent points.

Lemma 3.15. *The equivalence of extremal assignments is an equivalence relation.*

Proof. From the definition, $Z \sim Z$ and $Z_1 \sim Z_2 \Rightarrow Z_2 \sim Z_1$ are clear. Suppose that $Z_1 \sim Z_2$ and $Z_2 \sim Z_3$. Suppose that v_1, v_2 are two adjacent 3-valent vertices in $Z_1(G) \setminus Z_3(G)$. Let $G' \in S(n)$ be the graph obtained by contracting v_1, v_2 to a 4-valent vertex w from G . Then $w \in Z_1(G')$. Since w is a 4-valent vertex, $Z_1(G') = Z_2(G') = Z_3(G')$. From $w \in Z_3(G')$, $v_1, v_2 \in Z_3(G)$, so there arises a contradiction. So only one of v_1 and v_2 can be in $Z_1(G) \setminus Z_3(G)$ and $Z_1(G) \setminus Z_3(G)$ is a union of isolated 3-valent points. $Z_3(G) \setminus Z_1(G)$ is the same. \square

The below proposition justifies the definition of the equivalence relation.

Proposition 3.16. *Let Z_1, Z_2 be two extremal assignments. If $Z_1 \sim Z_2$, then there is a homeomorphism between $\overline{M}_{0,n}(Z_1)$ and $\overline{M}_{0,n}(Z_2)$, which preserves $M_{0,n}$. In this case, if X^ν is the normalization of X , then $\overline{M}_{0,n}(Z_1)^\nu \cong \overline{M}_{0,n}(Z_2)^\nu$.*

Proof. Suppose that $Z_1 \sim Z_2$. Let $Z_3 := Z_1 \cap Z_2$. Then it is straightforward to check that $Z_1 \sim Z_3 \sim Z_2$. By Proposition 3.9, we have two morphisms

$$(1) \quad \begin{array}{ccc} & \overline{M}_{0,n}(Z_3) & \\ \pi_{Z_3, Z_2} \swarrow & & \searrow \pi_{Z_3, Z_1} \\ \overline{M}_{0,n}(Z_1) & & \overline{M}_{0,n}(Z_2). \end{array}$$

These are surjective since they are dominant morphisms between proper varieties. For $X := (C, x_1, x_2, \dots, x_n) \in \overline{M}_{0,n}(Z_3)$, two maps π_{Z_3, Z_1} and π_{Z_3, Z_2} contract 3-pointed components of X only. Since there is no positive-dimensional moduli on 3-pointed rational curves, π_{Z_3, Z_1} and π_{Z_3, Z_2} are bijective.

Furthermore, since $\pi_{Z_i} : \overline{M}_{0,n} \rightarrow \overline{M}_{0,n}(Z_i)$ is a morphism from a smooth variety with connected fibers, the normalization map $\overline{M}_{0,n}(Z_i)^\nu \rightarrow \overline{M}_{0,n}(Z_i)$ is bijective. Therefore $\overline{M}_{0,n}(Z_3)^\nu \rightarrow \overline{M}_{0,n}(Z_i)^\nu$ is a bijective map between normal varieties, so it is an isomorphism. \square

If $Z_2 \subset Z_1$, unless $Z_1(G) \setminus Z_2(G)$ is a disjoint union of isolated 3 valent vertices, there is a further contraction on the moduli space. Thus $\pi_{Z_2, Z_1} : \overline{M}_{0,n}(Z_2) \rightarrow \overline{M}_{0,n}(Z_1)$ is not injective. Thus we have the following partial converse.

Proposition 3.17. *Suppose that $Z_2 \subset Z_1$ and the reduction map $\pi_{Z_2, Z_1} : \overline{M}_{0,n}(Z_2) \rightarrow \overline{M}_{0,n}(Z_1)$ is bijective. Then $Z_1 \sim Z_2$.*

4. EXAMPLES

Before investigating their combinatorics, we leave some important classes of examples of extremal assignments.

4.1. Trivial assignment. If $Z(G) = \emptyset$ for every $G \in S(n)$, then there is no contracted component on any $(C, x_1, x_2, \dots, x_n) \in \overline{M}_{0,n}$. Therefore $\overline{M}_{0,n}(Z) = \overline{M}_{0,n}$.

4.2. Weight assignments. In [Has03], Hassett introduced a large family of modular contractions of $\overline{M}_{0,n}$.

Definition 4.1. Fix weight data $A = (a_1, a_2, \dots, a_n)$, that is, a sequence of $a_i \in \mathbb{Q}$ such that $0 < a_i \leq 1$ and $\sum a_i > 2$. A pointed curve $(C, p_1, p_2, \dots, p_n)$ is *A-stable* if

- (1) C is a connected, projective curve of arithmetic genus zero with at worst nodal singularities;
- (2) p_i 's are all smooth points on C ;
- (3) For any smooth point $x \in C$, $\sum_{p_i=x} a_i \leq 1$;
- (4) For every irreducible component K of C , the number of singular points plus $\sum_{p_i \in K} a_i$ is greater than 2.

Let $\overline{M}_{0,A}$ be the moduli space of *A-stable* curves.

Remark 4.2. It is straightforward to check that $\overline{M}_{0,A} = \overline{M}_{0,n}$ if $A = (1, 1, \dots, 1)$.

Theorem 4.3 ([Has03, Theorem 4.1]). *For any weight data $A = (a_1, a_2, \dots, a_n)$,*

- (1) $\overline{M}_{0,A}$ is a smooth projective variety;
- (2) If $B = (b_1, b_2, \dots, b_n)$ is some other weight data such that $b_i \geq a_i$, there is a reduction map $\rho_{B,A} : \overline{M}_{0,B} \rightarrow \overline{M}_{0,A}$.

Any $\overline{M}_{0,A}$ can be described as $\overline{M}_{0,n}(Z)$ for some Z .

Definition 4.4. Let A be a collection of weight data. Define an extremal assignment Z_A as follows. For $G \in S(n)$,

$$Z_A(G) = \{v \in G \mid \exists \text{ a tail } T \subset G, v \in T, \sum_{i \in T} a_i \leq 1\}.$$

We will call Z_A a *weight assignment* from weight data A .

It was shown that $\overline{M}_{0,A} = \overline{M}_{0,n}(Z_A)$ ([Smy13, Example 1.11]).

4.3. Kontsevich-Boggi compactification. Define $Z_B(G)$ as the set of all vertices without any labels on G . Then Z is an extremal assignment. The corresponding birational model $\overline{M}_{0,n}(Z_B)$ is called *Kontsevich-Boggi compactification*, which was introduced in [Bog99] with completely different terminology.

4.4. GIT compactifications. All of the above examples were unified and generalized in [GJM13]. There is a broader family of *Veronese quotients* or *GIT compactifications*. This is also a generalization of $(\mathbb{P}^1)^n // \mathrm{SL}_2$, which is a natural compactification of $M_{0,n}$ from the viewpoint of invariant theory. It contains $\overline{M}_{0,n}$ itself, Hassett's moduli spaces of weighted pointed curves, and Kontevich-Boggi compactification.

Fix a positive integer d . We fix $(\gamma, c_1, c_2, \dots, c_n) \in \mathbb{Q}^{n+1}$ such that $(d-1)\gamma + \sum c_i = d+1$ and $0 \leq \gamma < 1$ and $0 < c_i < 1$ for all i . For $G \in S(n)$ and its tail T , $c_T := \sum_{i \in T} c_i$. Assume that $\frac{c_T-1}{1-\gamma}$ is not an integer for any T (Remark 4.7). Define a degree of T as

$$(2) \quad \sigma(T) = \begin{cases} \lceil \frac{c_T-1}{1-\gamma} \rceil, & \text{if } 1 < c_T < c_{[n]} - 1, \\ 0, & \text{if } c_T < 1, \\ d, & \text{if } c_T > c - 1. \end{cases}$$

Note that any vertex $v \in V(G)$ is a difference of two tails $T_1 \subset T_2$, so we may define $\sigma(v) := \sigma(T_2) - \sigma(T_1)$. Two combinatorial results in [GJM13, Section 3] are:

- (1) The degree function $\sigma : V(G) \rightarrow \mathbb{Z}$ is well-defined;
- (2) $\sum_{v \in V(G)} \sigma(v) = d$.

Definition 4.5. Define an assignment $Z_{\gamma, \vec{c}}$ as the following:

$$Z_{\gamma, \vec{c}}(G) = \{v \in V(G) \mid \sigma(v) = 0\}$$

Then it is indeed an extremal assignment ([GJM13, Proposition 5.7]).

Theorem 4.6 ([GJM13, Theorem 1.1, Theorem 5.2]). *For any parameters $d \in \mathbb{N}$ and $(\gamma, \vec{c}) \in \mathbb{Q}_{>0}^{n+1}$ such that $(d-1)\gamma + \sum c_i = d+1$, there is a projective variety $V_{\gamma, \vec{c}}^d$ with a birational contraction morphism $\overline{M}_{0,n} \rightarrow V_{\gamma, \vec{c}}^d$ with connected fibers. The space $V_{\gamma, \vec{c}}^d$ is constructed as a GIT quotient $U_{d,n} //_{\gamma, \vec{c}} \mathrm{SL}_{d+1}$ where $U_{d,n}$ is an incidence variety in $\mathrm{Chow}_{1,d}(\mathbb{P}^d) \times (\mathbb{P}^d)^n$. Furthermore, if $\frac{c_T-1}{1-\gamma}$ is not an integer for every tail T of $G \in S(n)$, $V_{\gamma, \vec{c}}^d \cong \overline{M}_{0,n}(Z_{\gamma, \vec{c}})$.*

Remark 4.7. If $\frac{c_T-1}{1-\gamma}$ is an integer for some tail T , then σ is not well-defined. However, still $V_{\gamma, \vec{c}}^d$ has a moduli theoretic meaning in a weak sense, namely, as a good moduli space of an Artin stack. For the details, see [GJM13, Section 6.3].

5. $n = 5$ CASE

As a first nontrivial case, in this section we classify all equivalence classes of extremal assignments of order 5. Note that there are three topological types of 5-labeled trees.

Lemma 5.1. *Suppose that Z_1 and Z_2 are two extremal assignments of order 5 and both $Z_1(G) \setminus Z_2(G)$ and $Z_2(G) \setminus Z_1(G)$ are empty or isolated 3-valent for all $G \in S_2(5)$. Then $Z_1 \sim Z_2$.*

Proof. Suppose not. If $Z_1 \not\sim Z_2$, then there is a graph G with two adjacent 3-valent vertices v_1, v_2 in $Z_1(G) \setminus Z_2(G)$. Then $G \in S_3(5)$ and there is $G' \in S_2(5)$ such that $G \rightsquigarrow G'$ and $\{v_1, v_2\} \rightsquigarrow v'$. Then $\ell(v') = 4$ and $v' \in Z_1(G') \setminus Z_2(G')$. This makes a contradiction. \square

type	I	II	III
graph			
contained in	$S_1(5)$	$S_2(5)$	$S_3(5)$

TABLE 1. topological types of dual graphs in $S(5)$

Lemma 5.2. *Suppose that Z is an extremal assignment and $G_1, G_2 \in S_2(5)$. Assume that v_1, v_2 are 4-valent vertices of G_1 and G_2 respectively. Furthermore, the labels adjacent to v_1 are i, j, k and those adjacent to v_2 are k, ℓ, m . Then at most one of v_1, v_2 can be assigned.*

Proof. Suppose that $K \in S_3(5)$ is the common degeneration of G_1 and G_2 . If $v_1 \in Z(G_1)$ and $v_2 \in Z(G_2)$, then all of three vertices of K must be assigned. This violates the first condition of extremal assignments. \square

Proposition 5.3. *There are precisely 76 equivalence classes of extremal assignments of order 5.*

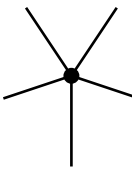
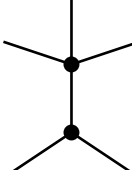
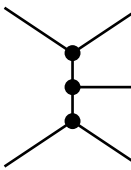
Proof. A subset $\mathcal{S} \subset \binom{[5]}{3}$ is called a *contraction indicator* if for any $B, B' \in \mathcal{S}$, $B \cup B' \neq [5]$ (The name will be justified soon). For each extremal assignment Z , we can construct $\mathcal{S}_Z \subset \binom{[5]}{3}$ such that $B \in \mathcal{S}_Z$ if and only if B is the set of labels adjacent to the 4-valent vertex $v \in V(G)$ and $v \in Z(G)$ for some $G \in S_2(5)$. Then by Lemma 5.2, \mathcal{S}_Z is a contraction indicator. Also from Definition 3.14, it is straightforward to see that $\mathcal{S}_Z = \mathcal{S}_{Z'}$ if $Z \sim Z'$. Conversely, by Lemma 5.1, if $\mathcal{S}_Z = \mathcal{S}_{Z'}$, then $Z \sim Z'$. Thus there is an injective map ϕ from the set of equivalence classes of extremal assignments of order 5 to the set of contraction indicators.

We show that for each contraction indicator \mathcal{S} there is an extremal assignment $Z_{\mathcal{S}}$ such that $\mathcal{S}_{Z_{\mathcal{S}}} = \mathcal{S}$. Define an assignment $Z_{\mathcal{S}}$ on $S_2(5)$ by $v \in Z_{\mathcal{S}}(G)$ if $G \in S_2(5)$, v is the 4-valent vertex of G , and the set B of three labels adjacent to v is in \mathcal{S} . We may extend $Z_{\mathcal{S}}$ to $S(5)$ by setting for any $H \in S_3(5)$, $w \in Z_{\mathcal{S}}(H)$ if there is $G \in S_2(5)$ such that $H \rightsquigarrow G$, $w \rightsquigarrow v$ and $v \in Z_{\mathcal{S}}(G)$. It is straightforward to check that $Z_{\mathcal{S}}$ is an extremal assignment. Thus ϕ in the previous paragraph is bijective.

For each contraction indicator $\mathcal{S} = \{B_i\}$, by taking the set of its complements $\{b_i\}$ where $b_i = B_i^c$, we obtain a subgraph of K_5 since $|b_i| = 2$. Furthermore, $B_i \cup B_j \neq [5]$ implies that $b_i \cap b_j \neq \emptyset$. Therefore, there is a one-to-one correspondence between the set of equivalence classes of extremal assignments of order 5 and

$$\mathcal{C} := \{H \mid H \text{ is a subgraph of } K_5, \text{ any two edges of } H \text{ meet}\}.$$

There are exactly three types of such graphs: the empty graph, stars, and K_3 's. There are $\binom{5}{2} + 5 \times \binom{4}{2} + 5 \times \binom{4}{3} + 5 = 65$ stars and $\binom{5}{3} = 10$ K_3 's. \square

Remark 5.4. This result will be generalized in Section 7 in terms of smooth extremal assignments.

Proposition 5.5. *Every $\overline{M}_{0,5}(Z)$ is isomorphic to $\overline{M}_{0,A}$ for some weight data A . In particular, every $\overline{M}_{0,5}(Z)$ is a smooth projective variety.*

Proof. Let k be the size of the associated contraction indicator. If $k = 0$, Z is an empty assignment and $\overline{M}_{0,5}(Z) = \overline{M}_{0,5}$. If $k = 1$, (say the corresponding contraction indicator is $\{\{1, 2, 3\}\}$) then $\overline{M}_{0,5}(Z) \cong \overline{M}_{0,((1/3)^3, 1^2)}$. If $k = 2$ and the contraction indicator is $\{\{1, 2, 3\}, \{1, 2, 4\}\}$, $\overline{M}_{0,5}(Z) \cong \overline{M}_{0,((1/4)^2, (1/2)^2, 1)}$. When $k = 3$, up to S_5 -action, there are two cases. If $\{\{1, 2, 3\}, \{1, 2, 4\}, \{1, 3, 4\}\}$ is assigned, then $\overline{M}_{0,5}(Z) \cong \overline{M}_{0,(1/5, (2/5)^3, 1)}$. If $\{\{1, 2, 3\}, \{1, 2, 4\}, \{1, 2, 5\}\}$ is assigned, then $\overline{M}_{0,5}(Z) \cong \overline{M}_{0,((1/6)^2, (2/3)^3)}$. Finally, if $k = 4$ and the contraction indicator is the set of 3-sets excluding 5, then $\overline{M}_{0,5}(Z) \cong \overline{M}_{0,((1/3)^4, 1)}$. \square

Remark 5.6. It is well-known that $\overline{M}_{0,5}$ is isomorphic to the blow-up of \mathbb{P}^2 along four general points. The 76 equivalence classes in Proposition 5.3, or equivalently, 76 birational contractions of $\overline{M}_{0,5}$ are in bijection with contractions of (-1) -curves on $\overline{M}_{0,5}$. Note that in the proof of Proposition 5.5, if $k = 1$, $\overline{M}_{0,A} = \text{Bl}_3\mathbb{P}^2$ and if $k = 2$, $\overline{M}_{0,A} = \text{Bl}_2\mathbb{P}^2$. If $k = 3$, $\overline{M}_{0,A}$ is either $\text{Bl}_1\mathbb{P}^2$ or $\mathbb{P}^1 \times \mathbb{P}^1$. Finally, if $k = 4$, $\overline{M}_{0,A} = \mathbb{P}^2$.

Remark 5.7. The number of extremal assignments is already huge. There are 15 type III graphs. We may freely assign an arbitrary number of central vertices to make an extremal assignment. Therefore the number of extremal assignments of order 5 is larger than 2^{15} . Note that all of these 2^{15} extremal assignments are equivalent to the empty assignment.

6. STRUCTURE THEOREM FOR EXTREMAL ASSIGNMENTS

In this section we will answer Question 1.1 and provide a structure theorem for extremal assignments, which will be useful to study concrete examples.

Let $G \in S(n) \setminus S_1(n)$ be a star and v be a central vertex of G . We say (G, v) is called a *basic pair*. For a basic pair (G, v) , we can assign a set partition $P := \{B_1, B_2, \dots, B_k\}$ where B_i is the set of labels on a tail of (G, v) . Note that $|P| \geq 3$ and there is B_i such that $|B_i| \geq 2$. Conversely, for any set partition P with $3 \leq |P| \leq n - 1$, we can construct a basic pair (G, v) . Let $\mathcal{P}(n)$ be the set of set partitions of $[n]$.

Example 6.1. Consider $G \in S_3(6)$ in Figure 6. For the basic pair (G, v_1) , the corresponding set partition is $P = \{\{1, 2\}, \{3\}, \{4\}, \{5, 6\}\}$. For (G', v') in Figure 6, the corresponding set partition is $P' = \{\{1\}, \{2\}, \{3\}, \{4\}, \{5, 6\}\}$.

Definition 6.2. Let (G, v) be a basic pair and let $P \in \mathcal{P}(n)$ be the associated set partition.

- (1) The *assignment generated by (G, v)* is an assignment Z_P defined by

$$Z_P(H) = \{w \in V(H) \mid \exists H \rightsquigarrow G, w \rightsquigarrow v\}.$$

It is not an extremal assignment in general.

- (2) The *atomic extremal assignment generated by (G, v)* is the smallest extremal assignment Z such that $v \in Z(G)$. The existence follows from the fact that any intersection of extremal assignments is an extremal assignment (Definition 3.4).

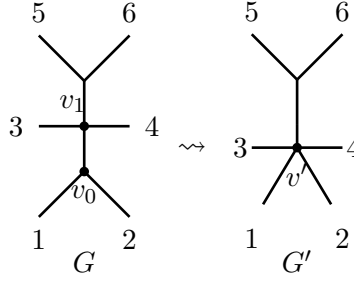

FIGURE 6. An example of contraction

Let $P = \{B_1, B_2, \dots, B_r\}$, $Q = \{C_1, C_2, \dots, C_s\}$ be two set partitions of $[n]$. We say $Q \leq P$ if for any $B_i \in P$, there is $C_j \in Q$ such that $B_i \subset C_j$. In this situation, we say that P is a *refinement* of Q and Q is a *corruption* of P . With respect to this partial order, $\mathcal{P}(n)$ is a partially ordered set. The maximum element is the complete partition $\{\{1\}, \{2\}, \dots, \{n\}\}$, and the minimum element is $\{\{n\}\}$.

Definition 6.3. We denote by $Q \preceq P$ if $Q \leq P$ and there is no $B \in Q$ such that B is a union of some singleton sets in P . In other words, if $P = \{\{i_1\}, \{i_2\}, \dots, \{i_r\}, B_1, B_2, \dots, B_s\}$ with $|B_i| \geq 2$, then there is no $B \in Q$ such that $|B| \geq 2$ and $B \subset \{i_1, i_2, \dots, i_r\}$.

Lemma 6.4. Let $Q \leq P$. Then there is $Q' \preceq P$ such that $Q \leq Q'$. Furthermore, $Z_Q \subset Z_{Q'}$.

Proof. If $B \in Q$ is a union of singleton sets in P , by splitting it into singleton sets, we obtain Q' . Let (G_Q, v_Q) (resp. $(G_{Q'}, v'_{Q'})$) be the basic pair associated to Q (resp. Q'). Then $G_Q \rightsquigarrow G_{Q'}$ and $v_Q \rightsquigarrow v'_{Q'}$. Therefore $Z_Q(G_Q) \subset Z_{Q'}(G_Q)$. This implies $Z_Q(G) \subset Z_{Q'}(G)$ for all G . \square

The following proposition describes the atomic extremal assignment generated by (G, v) .

Proposition 6.5. Let (G, v) be a basic pair with a set partition P . The atomic extremal assignment generated by (G, v) is

$$Z := \bigcup_{Q \leq P, |Q| \geq 3} Z_Q = \bigcup_{Q \preceq P, |Q| \geq 3} Z_Q.$$

Proof. For $Q \leq P$, let (G_Q, v_Q) be the associated basic pair.

Step 1. The second equality holds.

If $Q \leq P$, then for any $v \in Z_Q(G)$, by Lemma 6.4, there is Q' such that $v \in Z_{Q'}(G)$, $Q \leq Q'$ and $Q' \preceq P$. Thus we have

$$\bigcup_{Q \leq P, |Q| \geq 3} Z_Q \subset \bigcup_{Q \preceq P, |Q| \geq 3} Z_Q.$$

We leave the other inclusion to the reader to check.

Next we show that Z is indeed an extremal assignment.

Step 2. For every $H \in S(n)$, $Z(H) \neq V(H)$.

Assume that $Z(H) = V(H)$. Then by definition, $V(H) = \bigcup_{Q \preceq P, |Q| \geq 3} Z_Q(H)$, where $Z_Q(H) = \{v \in V(H) \mid \exists H \rightsquigarrow G_Q, v \rightsquigarrow v_Q\}$. For each vertex w_i adjacent to label i , $w_i \in Z_Q(H)$ for some

$Q \leq P$. Then Q has a singleton set $\{i\}$. Since P is a refinement of Q , $\{i\} \in P$. Therefore P is the complete partition, which is a contradiction. Therefore $Z(H) \neq V(H)$.

Step 3. If $\pi : H \rightsquigarrow H'$ and $\{v_1, v_2, \dots, v_k\} \rightsquigarrow v'$, then $v' \in Z(H')$ if and only if $\{v_1, v_2, \dots, v_k\} \in Z(H)$.

Suppose that $v' \in Z(H')$. By definition of Z , there is $Q \preceq P$ such that $H' \rightsquigarrow G_Q$, $v' \rightsquigarrow v_Q$. Then $H \rightsquigarrow G_Q$ and $\{v_1, v_2, \dots, v_k\} \rightsquigarrow v_Q$. Thus $v_1, v_2, \dots, v_k \in Z(H)$.

Conversely, assume that $\{v_1, v_2, \dots, v_k\} \in Z(H)$. We will use induction on k . Consider the case of $k = 1$. There is $Q \preceq P$ with corresponding basic pair (G_Q, v_Q) so that $q : H \rightsquigarrow G_Q$ and $v \rightsquigarrow v_Q$. On the other hand, let $(G_{Q'}, v_{Q'})$ be the basic pair obtained from H' by:

- Contracting all non-contracted vertices in $\pi(q^{-1}(v_Q))$ (including v') to a single vertex $v_{Q'}$;
- Contracting each tail connected to $v_{Q'}$ to a vertex.

Let Q' be the associated set partition. Then $Q' \leq Q$. Thus $Q' \leq P$ and $v' \in H'$ is in $Z(H')$. See Figure 7.

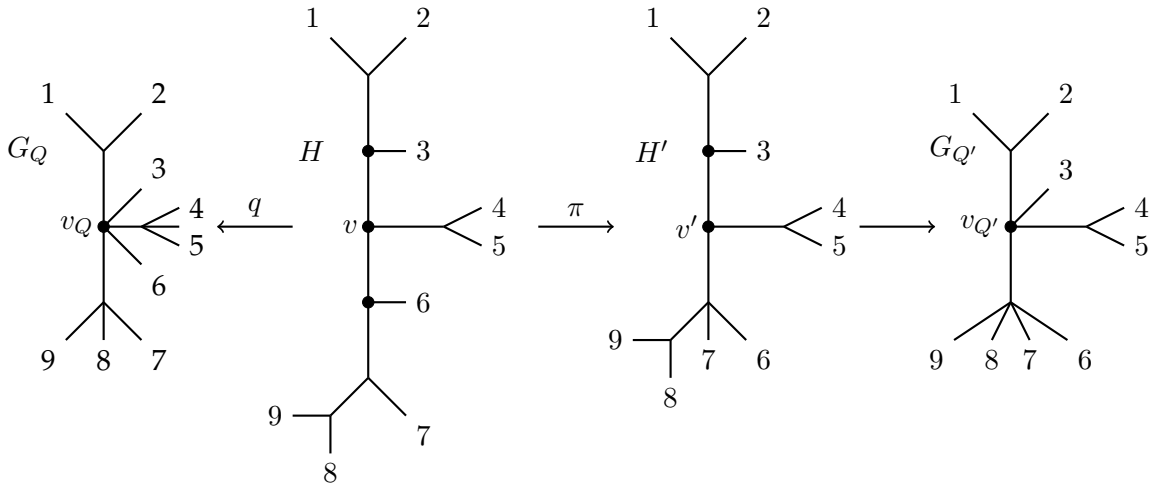

FIGURE 7. $k = 1$ case

Now consider a general case. Since $\{v_1, v_2, \dots, v_k\}$ forms a connected subgraph of H , there are two adjacent vertices (say v_1, v_2). Then by definition of Z , $v_1 \in Z_Q(H)$ and $v_2 \in Z_R(H)$ for some $Q, R \preceq P$. If $Q = R$, then we can contract v_1 and v_2 to a single vertex w and make a new graph \overline{H} . Then still $\overline{H} \rightsquigarrow G_Q$ and $w \rightsquigarrow v_Q$, thus $w \in Z(\overline{H})$. Now $\overline{H} \rightsquigarrow H'$ and $\{w, v_3, v_4, \dots, v_k\} \rightsquigarrow v'$. So it is reduced to the $k-1$ vertices case, which is true by the induction hypothesis. If $Z_Q(H) \cap Z_R(H) \neq \emptyset$, then both v_1, v_2 are in one of them, say, $Z_Q(H)$. Then if we replace R by Q , it is reduced to the $Q = R$ case.

Finally, suppose that $Z_Q(H) \cap Z_R(H) = \emptyset$. If $Q = \{C_1, C_2, \dots, C_s\}$ and $R = \{D_1, D_2, \dots, D_t\}$, then there are C_i and D_j such that $C_i = \bigcup_{k \neq j} D_k$ and $D_j = \bigcup_{k \neq i} C_k$. Since Q and R are corruptions of P , P is a refinement of $P' := \{C_k\}_{k \neq i} \cup \{D_k\}_{k \neq j}$. Then $P' \preceq P$ and for $H \rightsquigarrow G_{P'}$, both v_1, v_2 are contracted to the central vertex $v_{P'} \in V(G_{P'})$. Therefore, after replacing Q, R by P' , we are reduced to the case of $Q = R$.

Step 4. Z is the smallest extremal assignment such that $v \in Z(G)$.

Note that for any extremal assignment Z' with $v \in Z'(G)$, by applying degeneration/contraction operations, one can check that $v_Q \in Z'(G_Q)$ for $Q \preceq P$. By the second axiom of extremal assignments, the assignment Z_Q generated by (G_Q, v_Q) is contained in Z' . Therefore $Z = \bigcup_{Q \preceq P, |Q| \geq 3} Z_Q$ is in Z' . \square

Remark 6.6. Let Z be an atomic extremal assignment. Then for any $G \in S(n)$, $Z(G)$ is a connected subset of $V(G)$ if it is nonempty.

Every extremal assignment can be described using atomic extremal assignments.

Lemma 6.7. Any nonempty extremal assignment Z is a union of finitely many atomic extremal assignments.

Proof. For any $G \in S(n)$ and $v \in Z(G)$, take the maximal connected subset W of $Z(G)$ containing v . By contracting W to a single vertex v' , we obtain G' and $v' \in Z(G')$. By contracting each tail to a vertex adjacent to v' , we obtain a star G'' and a central vertex v'' so that $G \rightsquigarrow G''$, $v \rightsquigarrow v''$, and $v'' \in Z(G'')$. Let Z_v be the atomic extremal assignment generated by (G'', v'') . Then $v \in Z_v(G)$ and $Z_v \subset Z$, since it is the smallest extremal assignment where v is assigned. Now it is clear that

$$Z = \bigcup_{v \in Z(G), G \in S(n)} Z_v.$$

\square

- Definition 6.8.** (1) Two partitions $P, Q \in \mathcal{P}(n)$ are called *incompatible* if $P \not\leq Q$ and $Q \not\leq P$.
(2) For $P, Q \in \mathcal{P}(n)$, we say that R is a *common upper bound* if $P \leq R$ and $Q \leq R$. A common upper bound R is *tight* if every $B \in R$ is in either P or Q .
(3) Two partitions $P \neq Q \in \mathcal{P}(n)$ are *transversal* if P, Q do not have a tight common upper bound. P, Q are *strongly transversal* if for every $P' \preceq P, Q' \preceq Q$ such that $|P'|, |Q'| \geq 3$ and P' and Q' are incompatible, P' and Q' are transversal.

Proposition 6.9. Let Z be an extremal assignment.

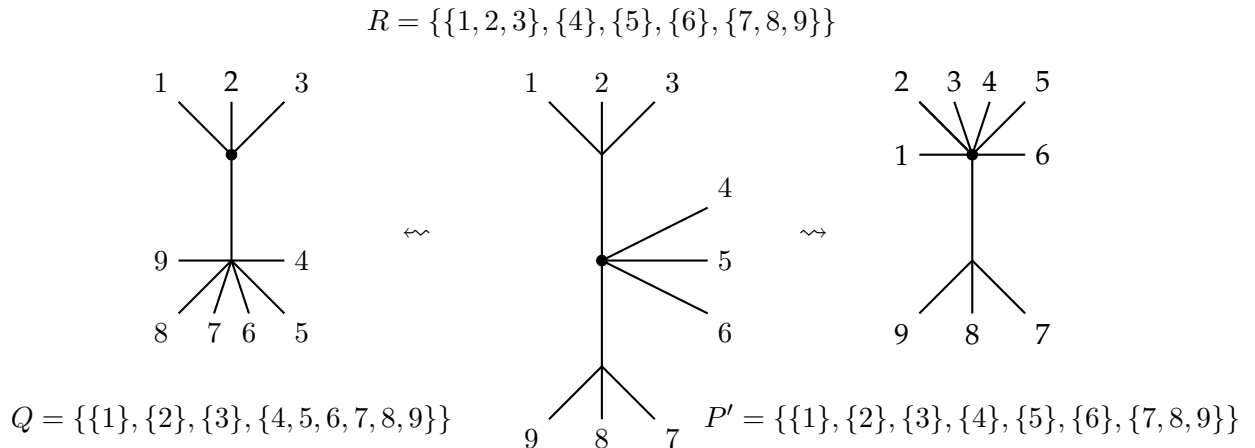

FIGURE 8. The case that $Z_Q(H) \cap Z_R(H) = \emptyset$ in Step 3.

- (1) There are finitely many atomic extremal assignments Z_1, Z_2, \dots, Z_k with corresponding set partitions P_1, P_2, \dots, P_k such that
- (a) P_i is not the complete partition;
 - (b) If $i \neq j$, P_i and P_j are incompatible;
 - (c) $Z = \bigcup_{i=1}^k Z_i$.
- (2) Suppose that $Q_i \preceq P_i$ and $Q_j \preceq P_j$. If R is a tight common upper bound of Q_i and Q_j , then $R \leq P_\ell$ for some P_ℓ .

Proof. The existence of finitely many atomic extremal assignments is obtained by Lemma 6.7. By Proposition 6.5, if $P_i \leq P_j$, then $Z_i \subset Z_j$. Therefore, by eliminating non-maximal P_i 's, we obtain a finite collection of set partitions satisfying (a), (b), and (c). This proves (1).

Let (G, v) be the basic pair associated to R . Then there is a degeneration $F \rightsquigarrow G$ such that

- (1) $\{v_1, v_2\} \rightsquigarrow v$;
- (2) Two basic pairs (F_i, w_i) and (F_j, w_j) associated to Q_i and Q_j respectively have the following property: there is a contraction $F \rightsquigarrow F_i$ (resp. $F \rightsquigarrow F_j$) so that $v_1 \rightsquigarrow w_i$ (resp. $v_2 \rightsquigarrow w_j$).

Since $w_i \in Z(F_i)$ and $w_j \in Z(F_j)$, $v_1, v_2 \in Z(F)$. Then $v \in Z(G)$. Therefore $v \in Z_\ell(G)$ for some ℓ . Then by Proposition 6.5, $R \leq P_\ell$. \square

The following is a converse.

Theorem 6.10. *Let $\{P_1, P_2, \dots, P_k\}$ be a set of incomplete set partitions of order n such that $P_i \not\leq P_j$ for any $i \neq j$. Let (G_i, v_i) be the basic pair corresponding to P_i and let Z_i be the atomic extremal assignment generated by (G_i, v_i) . Suppose that for any $i \neq j$ and $Q_i \preceq P_i$ and $Q_j \preceq P_j$, if R is a tight common upper bound of Q_i and Q_j , then there is P_ℓ such that $R \leq P_\ell$. Then $Z := \bigcup_{i=1}^k Z_i$ is extremal.*

Proof. Step 1. For every $H \in S(n)$, $Z(H) \neq V(H)$.

Assume not. So there exists H with $V(H) = Z(H) = \bigcup_{i=1}^k Z_i(H)$. Suppose that for $i \neq j$, $Z_i(H) \cap Z_j(H) \neq \emptyset$. Let $W = Z_i(H) \cap Z_j(H)$. Both $Z_i(H)$ and $Z_j(H)$ are connected subsets (Remark 6.6) of a tree; W is connected too. If $Z_i(H) \neq Z_j(H)$, then we may assume that there is $v' \in Z_i(H) \setminus Z_j(H)$ that is adjacent to $v \in W$. Let $H \rightsquigarrow \overline{H}$ be the contraction such that $\{v, v'\} \rightsquigarrow w$. Since Z_i, Z_j are extremal, $w \in Z_i(\overline{H})$ but $w \notin Z_j(\overline{H})$. But still $Z(\overline{H}) = V(\overline{H})$. By applying this procedure several times, we may assume that for two i and j , either $Z_i(H) = Z_j(H)$ or $Z_i(H) \cap Z_j(H) = \emptyset$.

Next, take a contraction $H \rightsquigarrow \overline{H}$ which contracts $Z_i(H)$ to a single vertex w_i . Then still $w_i \in Z_i(\overline{H})$ and $Z_j(\overline{H})$ can be identified with $Z_j(H)$. Thus $Z(\overline{H}) = V(\overline{H})$. Thus we may assume that each $Z_i(H)$ is a single vertex. Let $Z_i(H) = \{w_i\}$.

By contracting each tail connected to w_i into a single vertex, we can obtain a basic pair (F_i, w_i) whose corresponding set partition is $Q_i = \{C_1, C_2, \dots, C_s\}$. By Proposition 6.5, $Q_i \preceq P_i$. Similarly, we can construct a set partition $Q_j = \{D_1, D_2, \dots, D_t\} \preceq P_j$. Then there are C_i and D_j such that $C_i = \bigcup_{k \neq j} D_k$ and $D_j = \bigcup_{k \neq i} C_k$. So Q_i and Q_j are incompatible, but $R := \{C_k\}_{k \neq i} \cup \{D_k\}_{k \neq j}$ is a tight common upper bound of them. By the assumption, there is P_ℓ such that $R \leq P_\ell$.

On the other hand, if we contract w_i and w_j to a vertex x and contract each tail to a vertex, we obtain a basic pair (F, x) , which corresponds to R . Thus $x \in Z_\ell(F)$. Since $H \rightsquigarrow F$ and

$\{w_i, w_j\} \rightsquigarrow x$, we have $w_i, w_j \in Z_\ell(H)$. This makes a contradiction, since $Z_\ell(H)$ is a singleton set. Therefore $Z(H) \neq V(H)$.

Step 2. If $H \rightsquigarrow H'$ and $\{v_1, v_2, \dots, v_k\} \rightsquigarrow v'$, then $v' \in Z(H')$ if and only if $v_1, v_2, \dots, v_k \in Z(H)$. If $v' \in Z(H')$, then $v' \in Z_i(H')$ for some i . Then $v_1, v_2, \dots, v_k \in Z_i(H) \subset Z(H)$.

Conversely, suppose that $v_1, v_2, \dots, v_k \in Z(H)$. Take two adjacent vertices $v_1, v_2 \in Z(H)$. Then $v_1 \in Z_i(H)$ and $v_2 \in Z_j(H)$ for some i and j . If $i = j$, then contract v_1 and v_2 to a single vertex w and make a new graph \bar{H} . Then $\bar{H} \rightsquigarrow H'$, $w \rightsquigarrow v'$, and $w \in Z_i(\bar{H}) \subset Z(\bar{H})$. Therefore we can reduce to the $(k - 1)$ vertices case. If $Z_i(H) \cap Z_j(H) \neq \emptyset$, one of $Z_i(H)$ and $Z_j(H)$ (say $Z_i(H)$) contains both v_1 and v_2 , so by replacing $Z_j(H)$ by $Z_i(H)$, we can reduce to the $i = j$ case.

Suppose that $Z_i(H) \cap Z_j(H) = \emptyset$. Then as in Step 1, there is a basic pair (F_i, w_i) (resp. (F_j, w_j)) with corresponding set partition $Q_i \preceq P_i$ (resp. $Q_j \preceq P_j$) with a tight common upper bound $R \leq P_\ell$. Then $w_i \in Z_\ell(F_i)$ and $w_j \in Z_\ell(F_j)$. So $Z_i(H), Z_j(H) \subset Z_\ell(H)$. By replacing Z_i, Z_j by Z_ℓ , we can reduce to the $i = j$ case.

So we deduce to the case of $k = 1$. In this case $v_1 \in Z_i(H)$ implies $v' \in Z_i(H') \subset Z(H')$, since Z_i is extremal. \square

An immediate simple consequence is:

Corollary 6.11. *Let $\{P_1, P_2, \dots, P_k\}$ be a set of incomplete set partitions of order n such that $P_i \not\leq P_j$ for any $i \neq j$. Let (G_i, v_i) be the basic pair associated to P_i and let Z_i be the atomic extremal assignment generated by (G_i, v_i) . If P_i and P_j are strongly transversal for any $i \neq j$, then $Z := \bigcup_{i=1}^k Z_i$ is extremal.*

Proof. If $Q_i \preceq P_i$ and $Q_j \preceq P_j$ are incompatible, then by assumption there is no tight common upper bound. If $Q_i \leq Q_j$, then their tight common upper bound is Q_j . \square

Example 6.12. Let $P_1 = \{\{1, 2\}, \{3, 4\}, \{5, 6, 7, 8\}\}$ correspond to a basic pair (G_1, v_1) and $P_2 = \{\{1, 2, 3, 4\}, \{5, 6\}, \{7, 8\}\}$ correspond to (G_2, v_2) . Let Z_i be an atomic extremal assignment associated to (G_i, v_i) . Then there is a tight upper bound $P_3 = \{\{1, 2\}, \{3, 4\}, \{5, 6\}, \{7, 8\}\}$. We can degenerate the vertex in P_2 with labels $\{5, 6, 7, 8\}$ into two vertices labelled $\{5, 6\}$ and $\{7, 8\}$ to obtain a new graph H , with one of two central vertices assigned. However, we can degenerate the vertex in P_1 with labels $\{1, 2, 3, 4\}$ into two vertices labelled $\{1, 2\}$ and $\{3, 4\}$ to obtain H with only the other central vertex assigned. Thus, in the union of these extremal assignments both of these adjacent vertices are assigned. Then we can contract these vertices to obtain a star graph H' with central vertex w and corresponding partition P_3 . If the union is extremal, $w \in Z_1 \cup Z_2(H')$. But $w \notin Z_1(H')$ and $w \notin Z_2(H')$, so $Z_1 \cup Z_2$ is not an extremal assignment.

Due to Theorem 6.10, we can approach Question 1.1 for extremal assignments algorithmically.

Algorithm 6.13 (Existence/construction of the smallest extremal assignment). Let $G_1, G_2, \dots, G_k \in S(n)$ and $v_1 \in V(G_1), v_2 \in V(G_2), \dots, v_k \in V(G_k)$. We want to find the smallest extremal assignment Z such that $v_i \in Z(G_i)$, if there is one.

- (1) Contract each tail of G_i adjacent to v_i to a single vertex and make a basic pair (\bar{G}_i, v_i) . Let P_i be the corresponding set partition.

- (2) For the family $\mathcal{F} := \{P_1, P_2, \dots, P_k\}$, take $Q_i \preceq P_i$ and $Q_j \preceq P_j$ and compute the tight upper bound R , if it exists. Add R to \mathcal{F} .
- (3) Repeat step (2) until all tight upper bounds are in \mathcal{F} .
- (4) If \mathcal{F} contains the complete set partition $\{\{1\}, \{2\}, \dots, \{n\}\}$, such Z does not exist.
- (5) If \mathcal{F} does not contain the complete set partition, then eliminate non-maximal elements in \mathcal{F} .
- (6) Let Z_P be the atomic extremal assignment associated to P . Then $Z = \bigcup_{P \in \mathcal{F}} Z_P$ is the smallest extremal assignment.

The algorithm is implemented as a program in Sage. It can be found on the website of the first author:

<http://www.hanbommoon.net/publications/extremal>

7. SMOOTH EXTREMAL ASSIGNMENTS

In this section, we investigate a special class of extremal assignments that provides smooth contractions of $\overline{M}_{0,n}$.

7.1. Definition and basic properties.

Definition 7.1. An extremal assignment Z is called *smooth* if for any $G \in S(n)$ and $v \in Z(G)$, there is $G' \in S_2(n)$ and $v' \in Z(G')$ such that $G \rightsquigarrow G'$, $v \rightsquigarrow v'$.

A smooth extremal assignment is completely determined by its restriction to $S_2(n)$.

Lemma 7.2. Let Z_1, Z_2 be two smooth extremal assignments such that $Z_1(G) = Z_2(G)$ for all $G \in S_2(n)$. Then $Z_1 = Z_2$.

Proof. If $v \in Z_1(H)$ for some $H \in S(n)$, then there is $G \in S_2(n)$, $w \in Z_1(G)$ such that $H \rightsquigarrow G$ and $v \rightsquigarrow w$. Then $w \in Z_2(G)$, and from the second axiom of extremal assignments, $v \in Z_2(H)$. Therefore $Z_1 \subset Z_2$. By symmetry, $Z_2 \subset Z_1$. \square

An important family of smooth extremal assignments is given by weight assignments.

Lemma 7.3. Let Z_A be a weight assignment (Section 4.2) associated to weight data A . Then Z_A is smooth.

Proof. Let $G \in S(n)$ and $v \in Z_A(G)$. Then by Definition 4.4, there is a tail $T \subset G$ such that $v \in V(T)$. Note that any $v' \in V(T)$ is assigned too. Let $G' \in S_2(n)$ be a contraction of G obtained by contracting T to a single vertex w and contracting T^c to another vertex w' . By the second axiom of extremal assignments, $w \in Z_A(G')$. Therefore Z_A is smooth. \square

However, there are smooth extremal assignments that are not weight assignments.

Example 7.4. Suppose that $n = 6$. We assign two vertices of graphs in $S_2(6)$, whose label sets are $\{1, 2, 3\}$ and $\{2, 5, 6\}$. Then $Z = Z_{P_1} \cup Z_{P_2}$ is the union of two atomic extremal assignments generated by two partitions $P_1 := \{\{1\}, \{2\}, \{3\}, \{4, 5, 6\}\}$ and $P_2 := \{\{2\}, \{5\}, \{6\}, \{1, 3, 4\}\}$. It is straightforward to see that P_1 and P_2 are strongly transversal, so by Corollary 6.11, Z is indeed

an extremal assignment. If $Z = Z_A$ for some weight data $A = (a_1, a_2, \dots, a_6)$, then we have two inequalities:

$$a_1 + a_2 + a_3 \leq 1, \quad a_2 + a_5 + a_6 \leq 1.$$

We have

$$\frac{1}{2}(a_1 + a_3) \leq \frac{1}{2}(1 - a_2), \quad \frac{1}{2}(a_5 + a_6) \leq \frac{1}{2}(1 - a_2).$$

The left hand side is an average of two weights, so we know that at least one of a_1 and a_3 (resp. a_5 and a_6) must be less than the right hand side. Suppose that $a_1, a_5 \leq \frac{1}{2}(1 - a_2)$. Then

$$a_1 + a_5 \leq 1 - a_2 \Rightarrow a_1 + a_2 + a_5 \leq 1.$$

This implies that the vertex with label set $\{1, 2, 5\}$ must be assigned too.

Lemma 7.2 tells us that smooth extremal assignments can be described by simpler combinatorial data. Note that any graph $G \in S_2(n)$ is a star and any vertex $v \in V(G)$ can be a central vertex. If we take the set of labels adjacent to v , the collection of these sets determines the smooth extremal assignment.

Definition 7.5. A collection \mathcal{C} of subsets of $[n]$ is called a *contraction indicator* if it satisfies

- (1) For any $B \in \mathcal{C}$, $2 \leq |B| \leq n - 2$;
- (2) If $B \in \mathcal{C}$ and $B' \subset B$ with $|B'| \geq 2$, then $B' \in \mathcal{C}$;
- (3) For $B_1, B_2 \in \mathcal{C}$, $B_1 \cup B_2 \neq [n]$.

The following lemma is straightforward.

Lemma 7.6. Let Z be an extremal assignment. For $G \in S_2(n)$ such that $Z(G) \neq \emptyset$, let B_G be the set of all labels adjacent to the assigned vertex. Let $\mathcal{C} = \{B_G \mid G \in S_2(n)\}$. Then \mathcal{C} is a contraction indicator.

The converse is also true.

Proposition 7.7. Let \mathcal{C} be a contraction indicator. Define an assignment Z for $S(n)$ as

$$(3) \quad Z(G) = \{v \in V(G) \mid \exists H \in S_2(n), w \in V(H), \exists \ell(w) \in \mathcal{C}, G \rightsquigarrow H, v \rightsquigarrow w\}.$$

Then Z is a smooth extremal assignment.

Proof. Let $\mathcal{C}^M := \{B_1, B_2, \dots, B_k\}$ be the set of maximal elements in \mathcal{C} . Let $P_i = \{\{j\}\}_{j \in B_i} \cup \{B_i^c\}$ be the set partition consisting of singleton sets $\{j\}$ if $j \in B_i$ and B_i^c . Finally, let Z_i be the atomic extremal assignment corresponding to P_i .

First of all, we claim that $Z = \bigcup_{i=1}^k Z_i$. For any $v \in Z(G)$, from the definition of Z , there is $Q \in \mathcal{P}(n)$ such that $v \in Z_Q(G)$. From the maximality, we can find P_i such that $Q \preceq P_i$. Therefore $v \in Z_i(G)$. This implies $Z(G) \subset \bigcup_{i=1}^k Z_i(G)$. By definition of Z again, the opposite inclusion is straightforward to check.

Now we will show that P_1, P_2, \dots, P_k are pairwise strongly transversal. Let $Q_i \preceq P_i$, $Q_j \preceq P_j$ and Q_i and Q_j be incompatible. Since P_i has only one non-singleton set B_i^c , Q_i has only one non-singleton set $C_i \supset B_i^c$ too from Definition 6.3. Similarly, P_j has B_j^c and Q_j has $C_j \supset B_j^c$. Because $C_i^c, C_j^c \in \mathcal{C}$, we have $C_i^c \cup C_j^c \neq [n]$. Thus $C_i \cap C_j \neq \emptyset$. If $C_i \subset C_j$, then $Q_i \leq Q_j$. Therefore $C_i \not\subset C_j$ and $C_j \not\subset C_i$. Therefore Q_i and Q_j do not have a tight common refinement.

By Corollary 6.11, the union Z is extremal. \square

Smooth assignments are special among extremal assignments because of the following result.

Theorem 7.8. *The birational model $\overline{M}_{0,n}(Z)$ is smooth if and only if Z is equivalent to a smooth extremal assignment.*

Proof. Suppose that Z is smooth. Any $(C, x_1, \dots, x_n) \in \overline{M}_{0,n}(Z)$ is obtained from $(C^s, x_1^s, \dots, y_n^s) \in \overline{M}_{0,n}$ by contracting some (not necessarily irreducible) tails. In particular, C is a nodal curve and x_i 's are not necessarily distinct smooth points on C . Since the stack of nodal curves with smooth marked points is smooth, $\overline{M}_{0,n}(Z)$ is smooth.

Conversely, suppose that $\overline{M}_{0,n}(Z)$ is a smooth algebraic space. Let $Z_d \subset Z$ be an assignment (so-called *smooth part of Z*) where $v \in Z_d(G)$ if and only if there is $H \in S_2(n)$ and $w \in Z(H)$ such that $G \rightsquigarrow H$ and $v \rightsquigarrow w$. We claim that Z_d is a smooth extremal assignment. For $G \in S_2(n)$, $Z(G) = Z_d(G)$. So by Lemma 7.6, Z_d on $S_2(n)$ defines a contraction indicator. By Proposition 7.7, it is uniquely extended to a smooth extremal assignment Z_d .

The contraction map $\pi_Z : \overline{M}_{0,n} \rightarrow \overline{M}_{0,n}(Z)$ factors through $\overline{M}_{0,n} \rightarrow \overline{M}_{0,n}(Z_d) \rightarrow \overline{M}_{0,n}(Z)$. If $\overline{M}_{0,n}(Z) \neq \overline{M}_{0,n}(Z_d)$, then $\overline{M}_{0,n}(Z)$ is a small contraction of $\overline{M}_{0,n}(Z_d)$, because it contracts an internal component with at least 4 special points, so the codimension of the exceptional set in $\overline{M}_{0,n}(Z_d)$ is at least 2. Note that $\overline{M}_{0,n}(Z_d)$ is a smooth space by the first part of the proof. A small contraction of a smooth space is singular. Therefore $\overline{M}_{0,n}(Z_d) = \overline{M}_{0,n}(Z)$. Thus Z_d is equivalent to Z by Proposition 3.17. \square

Because of Lemma 7.2, a smooth extremal assignment can be described by simpler combinatorial data. There is a correspondence between the set of smooth extremal assignments of order n and a set of well-studied combinatorial objects in hypergraph theory. We refer to [Ber89] for notations on hypergraphs.

Definition 7.9. *A simple intersecting family of order n , rank $\leq n - 2$, antirank ≥ 2 is a hypergraph $H = (V(H), E(H))$ whose vertex set is $V(H) = [n]$ and whose edge set is $E(H) = \{A_i\}$, and that satisfies:*

- (1) For any $A_i \in E(H)$, $2 \leq |A_i| \leq n - 2$;
- (2) H is simple (i.e., $A_i \subset A_j \Rightarrow i = j$);
- (3) $A_i \cap A_j \neq \emptyset$ for any $A_i, A_j \in E(H)$.

Theorem 7.10. *There is a bijection between the set of smooth extremal assignments of order n and the set of simple intersecting families of order n , rank $\leq n - 2$, antirank ≥ 2 .*

Proof. For a smooth extremal assignment Z , we can construct a contraction indicator \mathcal{C}_Z . Let $\mathcal{C}_Z^M = \{B \in \mathcal{C}_Z \mid B \subset B' \Rightarrow B = B'\}$, that is, the set of maximal elements. Then let $\mathcal{E}_Z = \{B^c \mid B \in \mathcal{C}_Z^M\}$. Then it is straightforward to check that \mathcal{E}_Z is a simple intersecting family. It is straightforward to check that this construction is reversible. \square

7.2. Projectivity of contractions. Although $\overline{M}_{0,n}(Z)$ is a smooth divisorial contraction of a smooth projective variety $\overline{M}_{0,n}$ when Z is smooth, in general it is not a projective variety. In particular, it does not appear in Mori's program (or the log minimal model program) for $\overline{M}_{0,n}$. In this section, we show the projectivity of some $\overline{M}_{0,n}(Z)$.

Lemma 7.11. *Let Z_1, Z_2 be two smooth extremal assignments such that $Z_1 \subset Z_2$. Let C_i be the corresponding contraction indicator for Z_i . Suppose that either one of the following two conditions holds.*

- (1) $C_2 = C_1 \cup \{B' \mid B' \subset B, |B'| \geq 2\}$ where $|B| = 3$;
- (2) $C_2 \setminus C_1 = \{B\}$ with $|B| \geq 4$.

Then the reduction map $\pi_{Z_1, Z_2} : \overline{M}_{0,n}(Z_1) \rightarrow \overline{M}_{0,n}(Z_2)$ is a smooth blow-down.

Proof. We denote the image $\pi_{Z_i}(D_B)$ by D_B if the image is a divisor. For the first case, consider $D_B \subset \overline{M}_{0,n}(Z_1)$. Then $D_B \cong \overline{M}_{0,4}(Z_1^B) \times \overline{M}_{0,n-2}(Z_1^{B^c}) \cong \mathbb{P}^1 \times \overline{M}_{0,n-2}(Z_1^{B^c})$, and $\pi_{Z_1, Z_2}(D_B) \cong \overline{M}_{0,n-2}(Z_1^{B^c})$ (Remark 3.11). We compute the restriction of the normal bundle along the fiber \mathbb{P}^1 containing $x \in D_B$. To calculate it, it suffices to pick a general point $X = (C = C_1 \cup C_2, x_1, x_2, \dots, x_n)$ where $C_1 \in \overline{M}_{0,4}(Z_1^B)$ and $C_2 \in M_{0,n-2}$. In this case, the normal bundle to D_B is isomorphic to that in $\overline{M}_{0,n}$. Thus the restriction is $\mathcal{O}(-1)$. Therefore, by the Fujiki-Nakano criterion ([FN72]), it is a blow-down with 1-dimensional exceptional fibers, in the category of Moishezon manifolds, or equivalently, that of algebraic spaces.

In the second case, the exceptional set $D_B \subset \overline{M}_{0,n}(Z_1)$ is isomorphic to $\overline{M}_{0,|B|+1}(Z_1^B) \times \overline{M}_{0,n-|B|+1}(Z_1^{B^c})$. The extremal assignment Z_1^B is on the label set $B \cup \{p\}$. Note that every subset $C \subset B \cup \{p\}$ such that $|C| = |B| - 1$ and $p \notin C$ is assigned. Therefore $Z_1^B = Z_A$ with $A = ((\frac{1}{|B|-1})^{|B|}, 1)$, where the last weight is for p . Then $\overline{M}_{0,|B|+1}(Z_1^B) \cong \overline{M}_{0,A} \cong \mathbb{P}^{|B|-2}$ ([Has03, Section 6.1]). If we take a general point $X = (C = C_1 \cup C_2, x_1, x_2, \dots, x_n) \in D_B$ such that $C_2 \in M_{0,n-|B|+1}$, then locally the normal bundle to D_B is isomorphic to the normal bundle to D_B in $\overline{M}_{0,A'}$, where $A' = ((\frac{1}{|B|-1})^{|B|}, 1^{n-|B|})$. In this case, the restriction of the normal bundle to a fiber $\mathbb{P}^{|B|-2}$ is $\mathcal{O}(-1)$. Therefore this is a smooth blow-down, too. \square

Proposition 7.12. *Let Z, Z' be two smooth extremal assignments such that $Z \subsetneq Z'$. Then the reduction map $\pi_{Z, Z'} : \overline{M}_{0,n}(Z) \rightarrow \overline{M}_{0,n}(Z')$ is decomposed into a sequence of blow-downs.*

Proof. We will construct a sequence of contraction indicators C_0, C_1, \dots, C_m such that

- (1) $C_i \subset C_{i+1}$,
- (2) C_0 corresponds to Z and C_m corresponds to Z' ,
- (3) C_i and C_{i+1} satisfy one of two conditions in Lemma 7.11.

For any $B \in C_0$, there is $B' \in C_m$ such that $B \subset B'$. Suppose that $B \subsetneq B'$. Take a minimal $D \subset B'$ such that D is not in C_0 and $|D| \geq 3$. If $|D| = 3$, then set $C_1 := C_0 \cup \{D' \mid D' \subset D, |D'| \geq 2\}$. If $|D| \geq 4$, set $C_1 := C_0 \cup \{D\}$. We can repeat this procedure until we reach C_m .

This implies that there is a sequence of smooth extremal assignments $Z = Z_0 \subset Z_1 \subset \dots \subset Z_m = Z'$ such that

$$\overline{M}_{0,n}(Z) = \overline{M}_{0,n}(Z_0) \rightarrow \overline{M}_{0,n}(Z_1) \rightarrow \dots \rightarrow \overline{M}_{0,n}(Z_m) = \overline{M}_{0,n}(Z')$$

is a sequence of smooth blow-downs. \square

Corollary 7.13. *Let Z be a smooth extremal assignment and let A be weight data such that $Z \subset Z_A$. Then $\overline{M}_{0,n}(Z)$ is a smooth projective variety.*

Proof. By Proposition 7.12, we can find a sequence of smooth extremal assignments $Z = Z_0 \subset Z_1 \subset \cdots \subset Z_m = Z_A$ such that

$$\pi : \overline{M}_{0,n}(Z) = \overline{M}_{0,n}(Z_0) \rightarrow \overline{M}_{0,n}(Z_1) \rightarrow \cdots \rightarrow \overline{M}_{0,n}(Z_m) = \overline{M}_{0,n}(Z_A)$$

is a sequence of smooth blow-ups. Since $\overline{M}_{0,n}(Z_A) = \overline{M}_{0,A}$ is a projective variety and a blow-up of a projective variety is also projective, we obtain the result. \square

Example 7.14. There is a smooth extremal assignment Z without any larger weight assignment. Let $\{\{1, 3, 4, 5\}, \{2, 4, 5, 6\}, \{1, 5, 6, 7\}, \{2, 3, 5, 7\}\}$ be the set of maximal elements in the contraction indicator for Z . If there is a weight $A = (a_1, a_2, \dots, a_7)$ such that $Z \subset Z_A$, we have

$$a_1 + a_3 + a_4 + a_5 \leq 1, a_2 + a_4 + a_5 + a_6 \leq 1, a_1 + a_5 + a_6 + a_7 \leq 1, a_2 + a_3 + a_5 + a_7 \leq 1.$$

By adding all of them, we have

$$2\left(\sum_{i=1}^7 a_i\right) + 2a_5 \leq 4.$$

But since $\sum_{i=1}^7 a_i > 2$, we have $a_5 < 0$, which is impossible.

In Section 11, we present some non-projective examples.

We leave three sufficient conditions for the existence of a larger weight assignment, which guarantees the projectivity of the birational model.

Proposition 7.15. *Let Z be a smooth extremal assignment and let $\mathcal{C} = \{B_i\}_{1 \leq i \leq k}$ be the corresponding contraction indicator. Z has a larger weight assignment Z_A under any of following conditions:*

- (1) *There is a label $j \in [n]$ such that $j \notin \bigcup_{i=1}^k B_i$.*
- (2) *There is only one B_i containing j .*
- (3) *$|B_i| < n/2$ for all i .*

Proof. For each case, we construct weight data $A = (a_1, a_2, \dots, a_n)$ with the property $\sum_{k \in B_i} a_k \leq 1$. For case (1), assume that $j = 1$. Then $A = (1, \left(\frac{1}{n-2}\right)^{n-2})$ works. For (2), assume that $j = 1$ and $1 \in B_1$. Let $\ell := |B_1|$. Set

$$a_i = \begin{cases} 1 - (\ell - 1)\epsilon, & i = 1 \\ \epsilon, & i \in B_1 - \{1\} \\ \frac{1}{n-\ell} + \epsilon, & i \notin B_1 \end{cases}$$

for $0 < \epsilon \ll 1$. Finally, for (3), $A = \left(\left(\frac{2}{n} + \epsilon\right)^n\right)$ works. \square

8. TORIC BIRATIONAL MODELS AND GRAPH ASSOCIAHEDRA

In [LM00], Losev and Manin introduced a modular birational model $\overline{M}_{0,n}^{LM}$ of $\overline{M}_{0,n}$, which is a smooth projective *toric* variety whose corresponding polytope is the $(n-3)$ -dimensional permutohedron. This space is called the *Losev-Manin space* and it parametrizes n -pointed chains of rational

curves. Later Hassett described it as $\overline{M}_{0,A}$ with $A = \left(\left(\frac{1}{n-2}\right)^{n-2}, 1, 1\right)$ ([Has03]). In particular, there is a reduction map $\overline{M}_{0,n}^{LM} \rightarrow \mathbb{P}^{n-3}$ if we interpret \mathbb{P}^{n-3} as $\overline{M}_{0,\left(\left(\frac{1}{n-2}\right)^{n-1}, 1\right)}$ ([Has03, Section 6.1, 6.4]).

The Losev-Manin space was generalized as toric varieties associated to graph associahedra. Recall that for any rational n -dimensional polytope P , one can associate a complete toric variety $X(P)$ ([Ful93]). In particular, for any connected graph G with $n - 2$ vertices, one can associate a toric variety $X(PG)$ as the following.

Definition 8.1. Let G be a connected graph. A *tube* of G is a subset $B \subset V(G)$ which generates a connected subgraph of G . A tube B is trivial if $|B| = 1$.

Note that an edge of G is a nontrivial tube.

Let G be a connected graph such that $V(G) = [n]$. Then we can associate an $(n - 1)$ -dimensional polytope PG , a so-called *graph associahedron*. We start with an $(n - 1)$ -dimensional simplex $PG^{(0)}$ with n facets indexed by $[n]$. We can identify higher codimensional faces with subsets of $[n]$. Let T_i be the set of tubes in G of size $n - i$. Let $PG^{(1)}$ be the polytope obtained by truncating faces in T_{n-1} (vertices). Then $PG^{(i)}$ is obtained by truncating faces of $PG^{(i-1)}$ in T_{n-i} . Let $PG = PG^{(n-2)}$ (See [dRJR16, Construction 1]).

In particular, if $G = K_{n-2}$, $X(PG) = \overline{M}_{0,n}^{LM}$ ([Has03, Section 6.4]).

In [dRJR16, Theorem 1], it was shown that $X(PG) \cong \overline{M}_{0,A}$ if and only if G is an iterated cone over a discrete set. In this section, we show the following quick application of the theory of smooth extremal assignments.

Definition 8.2. A connected graph G is *co-transitive* if for any edge e and a vertex v , there is an edge f that connects v and one end point of e .

Lemma 8.3 is due to Andreas Blass and Daniel Soltész.

Lemma 8.3. A connected graph G is co-transitive if and only if it is a complete multipartite graph.

Proof. If G is co-transitive, then non-adjacency is transitive: If v and w are not adjacent and w and x are not adjacent, then v and x are not adjacent. Thus the complement graph of G is a disjoint union of cliques. Therefore G is complete multipartite. The converse is easy to check. \square

Lemma 8.4. Let G be a co-transitive graph. Then for any subset B' of a non-tube, B is also a non-tube.

Proof. If B' is a tube, then by using co-transitivity, we can enlarge B' to a tube B . \square

Theorem 8.5. For any connected graph G of $(n - 2)$ vertices, $X(PG) \cong \overline{M}_{0,n}(Z)$ for some smooth extremal assignment Z if and only if G is a complete multipartite graph.

Proof. Note that PG is obtained from an $(n - 3)$ -dimensional simplex by truncating faces in an increasing order of dimension. Dually, $X(PG)$ is obtained by taking successive blow-ups of torus invariant subvarieties of \mathbb{P}^{n-3} in an increasing order of dimension.

Let T be the set of tubes in G . Let

$$\mathcal{C} := \{B \cup \{n - 1\} \subset [n - 1] \mid B \notin T, |B| \geq 2\} \cup \{B' \subset [n - 2] \mid |B'| \geq 2\} \subset [n].$$

This set \mathcal{C} indexes the set of contracted divisors.

We claim that \mathcal{C} is a contraction indicator (Definition 7.5) if and only if G is co-transitive. If this is true, then $X(PG)$ is a smooth blow-up of $\mathbb{P}^{n-3} = \overline{M}_{0,((1/(n-2))^{n-1},1)}$ and it can be interpreted as $\overline{M}_{0,n}(Z)$, as in Proposition 7.12.

Items (1) and (3) of Definition 7.5 are clear from the definition, since $n \notin B$ for all $B \in \mathcal{C}$. So it suffices to check item (2).

Suppose that G is co-transitive. Assume that $B \in \mathcal{C}$ and $B' \subset B$ and $|B'| \geq 2$. If $B' \subset [n-2]$, then by definition, $B' \in \mathcal{C}$. If $n-1 \in B'$, then $B'' := B' \setminus \{n-1\}$ is a subset of a non-tube $B \setminus \{n-1\}$. Therefore B'' is also a non-tube by Lemma 8.4 and $B' \in \mathcal{C}$.

Conversely, suppose that \mathcal{C} is a contraction indicator. Let $e = \{i, j\}$ be an edge of G and let k be a vertex not on e . If there is no edge connecting e and k , then $\{i, j, k\}$ is not a tube. Then $\{i, j, k, n-1\} \in \mathcal{C}$. Since \mathcal{C} is a contraction indicator, $\{i, j, n-1\} \in \mathcal{C}$. So $\{i, j\}$ is not a tube, which is a contradiction. Therefore G is co-transitive. \square

For any connected graph G of order $n-2$, the corresponding toric variety $X(PG)$ is smooth, and it is a divisorial contraction of $X(PK_{n-2}) = \overline{M}_{0,n}^{LM}$. However, only very few of them have a moduli theoretic interpretation. This is further evidence that the current moduli-theoretic description of birational models is insufficient to understand birational geometric behavior of $\overline{M}_{0,n}$.

9. S_n -INVARIANT EXTREMAL ASSIGNMENTS

There is a natural S_n -action on $\overline{M}_{0,n}$, permuting n labels. Let $\widetilde{M}_{0,n}$ be the quotient space $\overline{M}_{0,n}/S_n$. This space has a natural moduli-theoretic interpretation as a moduli space of stable rational curves with unordered marked points, and the birational geometric properties are relatively simple compared to that of $\overline{M}_{0,n}$. For instance, the Picard number $\rho(\widetilde{M}_{0,n})$ is $\lfloor n/2 \rfloor - 1$, and the effective cone is simplicial. It is expected that $\widetilde{M}_{0,n}$ is a Mori dream space, in contrast to $\overline{M}_{0,n}$, which is not a Mori dream space for large n ([CT15]).

The S_n -action naturally induces S_n -actions on the set of stable n -labeled trees $S(n)$, the set of set partitions $\mathcal{P}(n)$, and the set of all (extremal) assignments of order n . Let Z be an S_n -invariant extremal assignment. Then the contraction map $\pi_Z : \overline{M}_{0,n} \rightarrow \overline{M}_{0,n}(Z)$ is S_n -equivariant. Therefore we have a quotient map $\widetilde{\pi}_Z : \widetilde{M}_{0,n} \rightarrow \overline{M}_{0,n}(Z)/S_n$. Thus S_n -invariant extremal assignments give contractions of $\widetilde{M}_{0,n}$. In this section, we study S_n -invariant extremal assignments.

In Section 6, we have seen that the structure of an extremal assignment can be described in terms of set partitions or, equivalently, basic pairs. Let (G, v) be a basic pair and suppose that $v \in Z(G)$ for an S_n -invariant extremal assignment Z . Since Z is S_n -invariant, for any permutation of n labels of G , the central vertex must be assigned too. Therefore the fact that a central vertex is assigned or not depends on the topological type of the underlying graph, not a specific labeling. Thus in the case of S_n -invariant assignments, a natural description is obtained in terms of integer partitions. This is a crucial difference between ordinary extremal assignments and invariant extremal assignments, because there are nontrivial automorphisms for the underlying tree without labeling.

Let $\mathcal{I}(n)$ be the set of integer partitions of n . For $p, q \in \mathcal{I}(n)$, we say $p \leq q$ if q is a finer partition than p . Then $\mathcal{I}(n)$ is a partially ordered set. The maximum element is the complete partition $\{1, 1, \dots, 1\}$, and the minimum element is $\{n\}$. We can define refinements, corruptions, and upper bounds of two integer partitions in a similar way.

Recall that $\mathcal{P}(n)$ is the set of set partitions of $[n]$. There is a natural forgetful map

$$f : \mathcal{P}(n) \rightarrow \mathcal{I}(n),$$

which maps $P = \{B_1, B_2, \dots, B_k\}$ to the partition $f(P) = \{|B_1|, |B_2|, \dots, |B_k|\}$. Then f is an S_n -invariant order-preserving map.

The following lemma explains relations between set partitions and integer partitions. The proof is straightforward.

Lemma 9.1. *Let $P, Q \in \mathcal{P}(n)$.*

- (1) *Suppose that $P \neq Q$ and $p = f(P), q = f(Q)$. Let $p = \{\lambda_1, \lambda_2, \dots, \lambda_s\}$ and $q = \{\mu_1, \mu_2, \dots, \mu_t\}$. Then p and q have a tight upper bound only if there are i and J with $|J| \geq 2$ such that $\lambda_i = \sum_{j \in J} \mu_j$ or vice versa.*
- (2) *If $f(P) \leq f(Q)$, then there is $\sigma \in S_n$ such that $P \leq \sigma \cdot Q$.*

As in the case of ordinary extremal assignments, one may try to define ‘atomic’ S_n -invariant extremal assignments. However, in contrast to the case of ordinary extremal assignments, it is not true that for any basic pair (G, v) , there is an S_n -invariant extremal assignment Z such that $v \in Z(G)$.

Example 9.2. Let (G, v) a basic pair with corresponding set partition $P = \{\{1, 2, 3\}, \{4\}, \{5\}, \{6\}\}$, and let Z be an S_n -invariant extremal assignment so that $v \in Z(G)$. We can permute the labels in P to obtain another basic pair (H, w) with set partition $P' = \{\{1\}, \{2\}, \{3\}, \{4, 5, 6\}\}$. If $v \in Z(G)$, then $w \in Z(H)$, by definition of an S_n -invariant extremal assignment. We can see that indeed $H = G$ and v and w are two vertices of G , so $Z(G) = V(G)$. Thus this basic pair has no S_n -invariant extremal assignment.

Let Z_G be the atomic extremal assignment associated to (G, v) . Then by Proposition 6.5, $Z_G = \bigcup_{Q \preceq P, |Q| \geq 3} Z_Q$, where P is the set partition corresponding to (G, v) . It is clear that any S_n -invariant extremal assignment contains $\bigcup_{\sigma \in S_n} \sigma \cdot Z_G = \bigcup_{\sigma \in S_n} Z_{\sigma \cdot G}$.

Definition 9.3. Let $p = \{\lambda_1, \lambda_2, \dots, \lambda_k\}$ be an integer partition of n .

- (1) A *replacement* of p is an integer partition of $[n]$ which is obtained by performing the following operation several times: Remove a subpartition $\{\lambda_i\}_{i \in I} \subset p$ and add another subpartition $\{\lambda_j\}_{j \in J} \subset p$ for two index sets I, J such that $\sum_{i \in I} \lambda_i = \sum_{j \in J} \lambda_j$.
- (2) An integer partition $\{\lambda_1, \lambda_2, \dots, \lambda_k\}$ of n is *special* if for any replacement r of p , $r \leq p$.
- (3) For a family $\mathcal{F} := \{p_1, p_2, \dots, p_m\}$ of integer partitions of $[n]$, a *replacement in \mathcal{F}* is an integer partition q_ℓ of $[n]$ which is obtained by performing the following operation several times: q_0 is any integer partition such that $q_0 \leq p_s$ for some s . q_{k+1} is obtained from q_k by removing a subpartition $\{\lambda_i\}_{i \in I} \subset p_s$ and adding another subpartition $\{\mu_j\}_{j \in J} \subset p_t$ for two index sets I, J such that $\sum_{i \in I} \lambda_i = \sum_{j \in J} \mu_j$.

(4) A family \mathcal{F} is called a *special family* if for any replacement r in \mathcal{F} , $r \leq p_j$ for some $p_j \in \mathcal{F}$.

Thus a singleton family $\mathcal{F} = \{p\}$ is special if and only if p is special.

- Example 9.4.** (1) Let $p_1 = \{4, 3, 2, 1\}$. Since $4 + 1 = 3 + 2$, $r_1 = \{4, 4, 1, 1\}$ and $r_2 = \{3, 3, 2, 2\}$ are replacements of p_1 . Since $r_2 \not\leq p_1$, p_1 is not special.
(2) Let $p_2 = \{6, 6, 1, 1\}$. Clearly the only replacement of p_2 is itself, so p_2 is special.
(3) Let $\mathcal{F} = \{p_1, p_2, p_3\}$ where $p_1 = \{3, 3, 3, 3, 2\}$, $p_2 = \{3, 3, 2, 2, 2, 2\}$, and $p_3 = \{2, 2, 2, 2, 2, 2\}$. It is easy to check that for any replacement r in \mathcal{F} , $r \leq p_1$, p_2 , or p_3 , so \mathcal{F} is a special family.
(4) Let $\mathcal{F} = \{p_1, p_2\}$ where $p_1 = \{5, 5, 2, 2\}$ and $p_2 = \{4, 4, 3, 3\}$. There is a replacement in \mathcal{F} , $r = \{5, 4, 3, 2\}$, such that $r \not\leq p_1$, $r \not\leq p_2$. Therefore \mathcal{F} is not a special family.

Theorem 9.5. Let $(G_1, v_1), (G_2, v_2), \dots, (G_k, v_k)$ be basic pairs and let p_1, p_2, \dots, p_k be the corresponding integer partitions. Let $Z_{p_i} := \bigcup_{\sigma \in S_n} \sigma \cdot Z_{G_i}$ where Z_{G_i} is the atomic extremal assignment associated to (G, v) . Then $Z := \bigcup_{i=1}^k Z_{p_i}$ is an S_n -invariant extremal assignment if and only if $\mathcal{F} := \{p_1, p_2, \dots, p_k\}$ is a special family.

Proof. By the construction, Z is S_n -invariant. Thus it suffices to check the extremality. Let P_i be the set partition corresponding to (G_i, v_i) .

Suppose that \mathcal{F} is a special family. Let $Q_1 \preceq \sigma_i \cdot P_i$ and $Q_2 \preceq \sigma_j \cdot P_j$. And let $p_i = f(P_i) = \{\lambda_1, \lambda_2, \dots, \lambda_s\}$ and $p_j = f(P_j) = \{\mu_1, \mu_2, \dots, \mu_t\}$. Suppose that Q_1, Q_2 have a tight upper bound R and $r := f(R)$. Let $q_1 := f(Q_1) = \{\nu_1, \nu_2, \dots, \nu_u\}$ and $q_2 := \{\xi_1, \xi_2, \dots, \xi_v\}$. By (1) of Lemma 9.1, there are several pairs (i, J) with $|J| \geq 2$ such that $\nu_i = \sum_{j \in J} \xi_j$ (or vice versa). Since $q_2 \leq p_j$, $\nu_i = \sum_{j \in J} \xi_j = \sum_{k \in K} \mu_k$ for some K . Thus r is a replacement of q_1 in \mathcal{F} . Since \mathcal{F} is a special family, $r \leq p_k$ for some k . By (2) of Lemma 9.1, there is $\tau \in S_n$ such that $R \leq \tau \cdot P_k$. By Theorem 6.10, Z is extremal.

Conversely, assume that Z is extremal. We claim that for any replacement r in \mathcal{F} and a corresponding basic pair (H, w) , $w \in Z(H)$. By induction, it is sufficient to show for a replacement r which is obtained by one operation. Let $q \leq p_i = \{\lambda_1, \lambda_2, \dots, \lambda_s\}$ and r be obtained by replacing $\{\lambda_i\}_{i \in I} \subset p_i$ and adding $\{\mu_j\}_{j \in J} \subset p_j$. Consider the following list of degenerations/contractions (Figure 9).

- (1) Start with (G_0, v_0) , which corresponds to q . $v_0 \in Z(G_0)$. Degenerate v_0 to two vertices v_1, v'_1 and obtain G_1 . $v_1, v'_1 \in Z(G_1)$. Here v_1 has tails indexed by I .
- (2) Contract v_1 and the tails connected to v_1 to a vertex v_2 and obtain (G_2, v'_2) . $v'_2 \in Z(G_2)$.
- (3) Degenerate v_2 and get G_3 where v_3 has tails indexed by J . $v'_3 \in Z(G_3)$.
- (4) Contract v'_3 and its tails to a vertex and obtain (G_4, v_4) . Since it corresponds to a partition $s \leq p_j$, $v_4 \in Z(G_4)$.
- (5) On G_3 , $v_3 \in Z(G_3)$ from (4).
- (6) By contracting v_3, v'_3 to v_5 , we obtain G_5 . $v_5 \in Z(G_5)$. G_5 corresponds to the replacement r .

Therefore if r is a replacement, then the corresponding central vertex is assigned. By Proposition 6.9, for R with $f(R) = r$, there must be $Z_P \subset Z$ so that $R \leq P$. Then $f(P) \leq p_k$ for some k and $r = f(R) \leq f(P) \leq p_k$. Therefore \mathcal{F} is special. \square

The following simple special case of Theorem 9.5 is already useful.

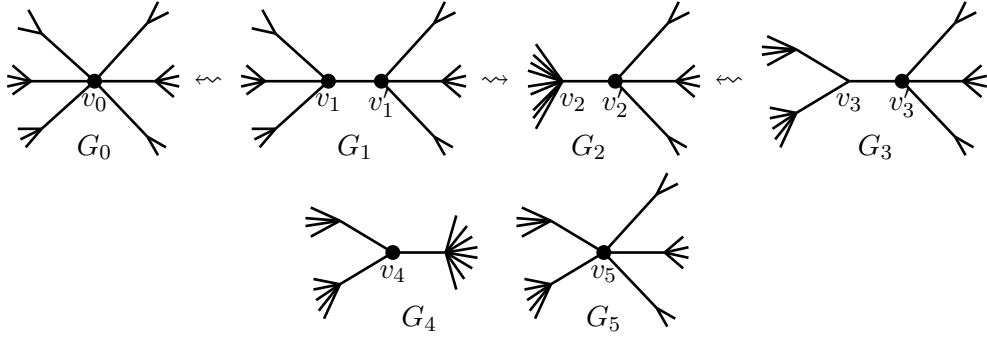

FIGURE 9. A sequence of contractions and degenerations

Corollary 9.6. *Let (G, v) be a basic pair. Let $Z := \bigcup_{\sigma \in S_n} \sigma \cdot Z_G$ as above and let p be the corresponding integer partition for (G, v) . Then Z is an extremal assignment if and only if p is special.*

Example 9.7. Let (G, v) be a basic pair with corresponding integer partition $p = \{4, 4, 3, 3\}$, and let $Z := \bigcup_{\sigma \in S_n} \sigma \cdot Z_G$. Clearly p is special, so Z is an extremal assignment.

Due to Theorem 9.5, we can translate Question 1.1 for S_n -invariant extremal assignments in terms of integer partitions.

Algorithm 9.8 (Existence/construction of the smallest extremal assignment). Let $G_1, G_2, \dots, G_k \in S(n)$ and $v_1 \in V(G_1), v_2 \in V(G_2), \dots, v_k \in V(G_k)$. We want to find the smallest S_n -invariant extremal assignment Z such that $v_i \in Z(G_i)$, if there is one.

- (1) Contract each tail of G_i adjacent to v_i to a single vertex and make a basic pair (\bar{G}_i, v_i) . Let p_i be the corresponding integer partition.
- (2) For the family $\mathcal{F} := \{p_1, p_2, \dots, p_k\}$, add all replacements of p_i in \mathcal{F} and enlarge \mathcal{F} .
- (3) If \mathcal{F} contains the complete partition $\{1, 1, \dots, 1\}$, then such Z does not exist.
- (4) If \mathcal{F} does not contain the complete partition, then eliminate non-maximal elements in \mathcal{F} .
- (5) $Z = \bigcup_{p \in \mathcal{F}} Z_p$ is the smallest S_n -invariant extremal assignment.

The algorithm is implemented as a program in Sage. It can be found on the website of the first author:

<http://www.hanbommoon.net/publications/extremal>

Although there are many new types of S_n -invariant extremal assignments, all S_n -invariant smooth assignments are already known.

Proposition 9.9. *Every S_n -invariant smooth extremal assignment is a weight assignment Z_A for some S_n -invariant weight A .*

Proof. Let Z be an S_n -invariant smooth extremal assignment, and let m be the largest number of labels on any assigned vertex. For any graph in $S_2(n)$, only the vertex with fewer labels can be assigned, otherwise we could permute the labels to show that the other vertex is assigned as well. So we have $n > 2m$. We can simply assign $A = ((\frac{1}{m})^n)$. We have $\sum a_i = \frac{n}{m} > \frac{2m}{m} = 2$. So A gives a valid weight assignment. \square

10. GEOGRAPHY OF CONTRACTIONS OF $\widetilde{M}_{0,n}$

Currently the two most generalized constructions of modular compactifications of $M_{0,n}$ are given by 1) extremal assignments and 2) Veronese quotients. They provide two large families of birational contractions of $\overline{M}_{0,n}$, large portions of which overlap. Since these two constructions are very general, one may wonder if these two families are sufficient to describe all birational contractions of $\overline{M}_{0,n}$. More precisely, we may ask the following question:

Question 10.1. Let X be a projective birational contraction of $\overline{M}_{0,n}$. Are there finitely many contractions $\overline{M}_{0,n} \rightarrow Y_i$ such that

- (1) Each Y_i is either (the normalization of) $\overline{M}_{0,n}(Z)$ or $V_{\gamma, \vec{c}}^d$;
- (2) X is (the normalization of) the image of the product map

$$\overline{M}_{0,n} \rightarrow \prod_{i=1}^k Y_i?$$

Remark 10.2. In projective birational geometry in the sense of Mori's program, if X is a normal projective variety and Y is a projective birational contraction of X , then Y is also a normal variety. Indeed, $Y = \text{Proj } \bigoplus_{m \geq 0} H^0(X, mD)$ for some big semi-ample divisor D , and the section ring is integrally closed. We do not know if $\overline{M}_{0,n}(Z)$ and $V_{\gamma, \vec{c}}^d$ are normal or not. Thus in Question 10.1, we must use normalizations of modular contractions. On the other hand, in both cases, the contraction map from $\overline{M}_{0,n}$ has a connected fiber, so the normalization $\overline{M}_{0,n}(Z)^\nu$ (resp. $(V_{\gamma, \vec{c}}^d)^\nu$) is homeomorphic to $\overline{M}_{0,n}(Z)$ (resp. $V_{\gamma, \vec{c}}^d$).

From this point, for notational simplicity, every modular compactification will be replaced by its normalization.

Remark 10.3. As we have seen in Section 8, extremal assignments are not sufficient to construct all projective birational contractions of $\overline{M}_{0,n}$.

We will see that the answer to Question 10.1 is negative even we restrict ourselves to S_n -invariant contractions, or equivalently, contractions of $\widetilde{M}_{0,n}$. In this section, we compute all faces of the nef cone of $\widetilde{M}_{0,n}$ for small n and try to find the corresponding contractions.

For $n = 4, 5$, the Picard number $\rho(\widetilde{M}_{0,n})$ is one. Thus there is no nontrivial contraction.

Example 10.4 ($n = 6$). In this case, the Picard number $\rho(\widetilde{M}_{0,6}) = \dim N^1(\widetilde{M}_{0,6}) = 2$. $F_{3,1,1,1}$ and $F_{2,2,1,1}$ generate two extremal rays of $\text{NE}_1(\widetilde{M}_{0,6})$. Dually, $\text{Nef}(\widetilde{M}_{0,6})$ is generated by $D_2 + 3D_3$ and $2D_2 + D_3$. The S_6 -quotient $\widetilde{M}_{0,6}$ is isomorphic to \overline{M}_2 and its rational contractions has been completely described by Hassett in [Has05]. Before taking S_6 -quotient, for $\overline{M}_{0,6}$, the birational model corresponding to $D_2 + 3D_3$ is $(\mathbb{P}^1)^6 // \text{SL}_2$, which is classically known as the Segre cubic. The model corresponding to $2D_2 + D_3$ is $V_{0,(3/7)^7}^2$, which is the Igusa quartic ([Moo15]). Both birational models do not come from extremal assignments. Indeed, any S_6 -invariant extremal assignment is equivalent to the empty assignment.

Example 10.5 ($n = 7$). In this case, $\rho(\widetilde{M}_{0,7})$ is two. There are three types of F-curves, $F_{4,1,1,1,1}$, $F_{3,2,1,1,1}$, and $F_{2,2,2,1,1}$. $F_{4,1,1,1,1}$ and $F_{2,2,2,1,1}$ generate two extremal rays of $\text{NE}_1(\widetilde{M}_{0,7})$. $\text{Nef}(\widetilde{M}_{0,7})$ is generated by $D_2 + 3D_3$ and $D_2 + D_3$. The model corresponding to $D_2 + 3D_3$ is $\overline{M}_{0,(1/3)^7}$. The model corresponding

to $D_2 + D_3$ is $\overline{M}_{0,7}(Z)$ where Z is the S_7 -invariant extremal assignment contracting the spine of $F_{2,2,2,1}$. So all contractions of $\widetilde{M}_{0,7}$ are obtained from extremal assignments.

Example 10.6 ($n = 8$). The nef cone is a 3-dimensional cone generated by 4 extremal rays $6D_2 + 11D_3 + 8D_4$, $3D_2 + 2D_3 + 4D_4$, $D_2 + 3D_3 + 6D_4$, and $2D_2 + 6D_3 + 5D_4$ (Figure 10). There are 8 proper faces of the nef cone. The corresponding birational contractions are listed in Table 2. Therefore for $n \leq 8$, the answer to Question 10.1 is affirmative for S_n -invariant contractions.

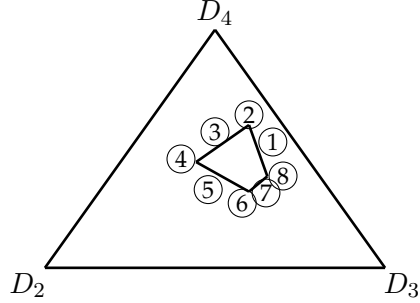

FIGURE 10. Nef cone and effective cone of $\widetilde{M}_{0,8}$

face	contracted F-curves	birational model
1	$F_{5,1,1,1}$	$\overline{M}_{0,((1/3)^8)}/S_8$
2	$F_{4,2,1,1}, F_{5,1,1,1}$	$(\mathbb{P}^1)^8//\mathrm{SL}_2/S_8 = \mathbb{P}^8//\mathrm{SL}_2$
3	$F_{4,2,1,1}$	Image of $\widetilde{M}_{0,8}$ in $((\mathbb{P}^1)^8//\mathrm{SL}_2 \times V_{0,(1/2)^8}^3)/S_8$
4	$F_{2,2,2,2}, F_{3,2,2,1}, F_{4,2,1,1}$	$V_{0,(1/2)^8}^3/S_8$
5	$F_{2,2,2,2}$	$\overline{M}_{0,8}(Z)/S_8$ where Z is generated by $\{2, 2, 2, 2\}$
6	$F_{3,3,1,1}, F_{2,2,2,2}$	$V_{0,(3/8)^8}^2/S_8$
7	$F_{3,3,1,1}$	$\overline{M}_{0,8}(Z)/S_8$ where Z is generated by $\{3, 3, 1, 1\}$
8	$F_{5,1,1,1}, F_{3,3,1,1}$	$V_{1/3,(1/3)^8}^2/S_8$

TABLE 2. List of contractions of $\widetilde{M}_{0,8}$

Example 10.7 ($n = 9$). The nef cone is a 3-dimensional cone generated by 4 extremal rays $3D_2 + 3D_3 + 4D_4$, $D_2 + D_3 + 2D_4$, $D_2 + 3D_3 + 6D_4$, and $D_2 + 3D_3 + 2D_4$ (Figure 11). There are 8 faces of the nef cone. The corresponding birational contractions are listed in Table 3.

Note that three faces are obtained from neither extremal assignments nor Veronese quotients. By using results in Section 9, it is straightforward to see that there is no S_n -invariant extremal assignment which contracts the given F-curves only. On the other hand, Veronese quotients may provide contractions which are not from extremal assignments. This occurs if there are strictly semistable points, or equivalently, if the quantity $\frac{c_T-1}{1-\gamma}$ has an integer value for some T (Remark 4.7). If it is an integer i and $|T| = k$, then

$$(d-1)\gamma + nc = d+1, \quad \frac{kc-1}{1-\gamma} = i$$

where $\vec{c} = (c, c, \dots, c)$. We can find all possible solutions for γ and c if we fix d, k , and i . Furthermore, if $d > 2n - 3$, then any parametrized curve has nodal singularities without marked points only ([GJM13, Corollary 2.7]). Therefore the possible models are Hassett's moduli spaces of weighted stable curves. Thus it suffices to check finitely many d, k , and i . For each solution, by using [GJMS13, Theorem 2.1], one can compute the set of contracted F-curves.

Therefore we can conclude that the answer to Question 10.1 is negative for $n \geq 9$ in general.

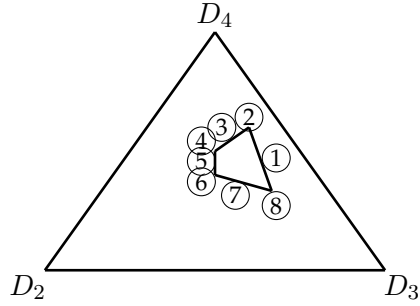

FIGURE 11. Nef cone and effective cone of $\tilde{M}_{0,9}$

face	contracted F-curves	birational model
1	$F_{6,1,1,1}$	$\overline{M}_{0,((1/3)^9)}/S_9$
2	$F_{6,1,1,1}, F_{5,2,1,1}$	$\overline{M}_{0,((1/4)^9)}/S_9 = (\mathbb{P}^1)^9//\mathrm{SL}_2/S_9 = \mathbb{P}^9//\mathrm{SL}_2$
3	$F_{5,2,1,1}$	not obtained from assignments or GIT
4	$F_{5,2,1,1}, F_{4,2,2,1}$	not obtained from assignments or GIT
5	$F_{4,2,2,1}$	not obtained from assignments or GIT
6	$F_{4,2,2,1}, F_{3,2,2,2}$	$\overline{M}_{0,9}(Z)/S_9$ where Z is generated by $\{2, 2, 2, 2, 1\}$
7	$F_{3,2,2,2}$	$\overline{M}_{0,9}(Z)/S_9$ where Z is generated by $\{3, 2, 2, 2\}$
8	$F_{3,2,2,2}, F_{6,1,1,1}, F_{4,3,1,1}, F_{3,3,2,1}$	$V_{0,(1/3)^9}^2/S_9$

TABLE 3. List of contractions of $\tilde{M}_{0,9}$

Example 10.8 ($n = 10$). In this case, the Picard number is 4. The f -vector of a slice of the nef cone is $(1, 7, 13, 8, 1)$ (Figure 12). In particular, the nef cone has 7 extremal rays. Table 4 gives us the list of contracted curves and the corresponding birational models for all extremal rays.

Example 10.9 ($n = 11$). Again, the Picard number is 4 and the f -vector of a slice of the nef cone is $(1, 10, 16, 8, 1)$ (Figure 12). So the nef cone has 10 extremal rays. Table 5 is the list of contracted curves and the corresponding birational models for all extremal rays.

11. NON-PROJECTIVE EXAMPLES

A priori, for an extremal assignment Z , the birational contraction $\overline{M}_{0,n}(Z)$ exists in the category of algebraic spaces (Theorem 3.7). There are indeed many examples in which $\overline{M}_{0,n}(Z)$ is not a projective variety. In this section, we present several examples of non-projective birational models.

There is a smooth extremal assignment Z which provides a non-projective birational model.

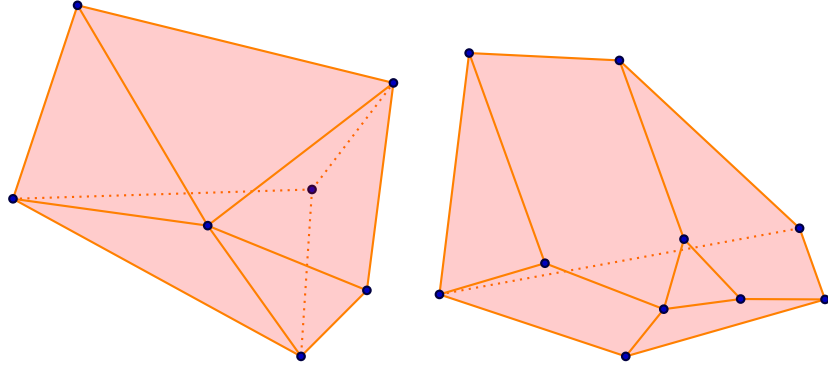
FIGURE 12. Slices of the nef cones of $\tilde{M}_{0,10}$ and $\tilde{M}_{0,11}$

contracted F-curves	birational model
$F_{4,2,2,2}, F_{3,3,3,1}, F_{3,3,2,2}$	not obtained from assignments or GIT
$F_{7,1,1,1}, F_{4,4,1,1}, F_{3,3,3,1}, F_{3,3,2,2}$	$V_{0,(3/10)^{10}}^2/S_{10}$
$F_{5,3,1,1}, F_{5,2,2,1}, F_{4,2,2,2}, F_{3,3,3,1}$	$V_{0,(2/5)^{10}}^3/S_{10}$
$F_{7,1,1,1}, F_{5,3,1,1}, F_{3,3,3,1}$	$V_{1/3,(1/3)^{10}}^3/S_{10}$
$F_{7,1,1,1}, F_{6,2,1,1}, F_{5,3,1,1}, F_{5,2,2,1}$	$(\mathbb{P}^1)^{10} // \text{SL}_2 / S_{10} = \mathbb{P}^{10} // \text{SL}_2$
$F_{6,2,1,1}, F_{5,2,2,1}, F_{4,4,1,1}, F_{4,3,2,1}, F_{4,2,2,2}, F_{3,3,2,2}$	$V_{0,(1/2)^{10}}^4/S_{10}$
$F_{7,1,1,1}, F_{6,2,1,1}, F_{4,4,1,1}$	$V_{1/2,(1/4)^{10}}^2/S_{10}$

TABLE 4. List of contractions of $\tilde{M}_{0,10}$ corresponding to extremal rays

contracted F-curves	birational model
$F_{4,4,2,1}, F_{4,3,2,2}, F_{3,3,3,2}$	not obtained from assignments or GIT
$F_{8,1,1,1}, F_{5,4,1,1}, F_{4,4,2,1}, F_{3,3,3,2}$	$V_{0,(3/11)^{11}}^2/S_{11}$
$F_{5,2,2,2}, F_{4,3,2,2}, F_{3,3,3,2}$	$\bar{M}_{0,11}(Z)/S_{11}$ for Z generated by $\{3, 2, 2, 2\}$ and $\{3, 3, 3, 2\}$
$F_{6,3,1,1}, F_{5,2,2,2}, F_{4,3,3,1}, F_{3,3,3,2}$	$V_{0,(4/11)^{11}}^3/S_{11}$
$F_{8,1,1,1}, F_{6,3,1,1}, F_{4,3,3,1}, F_{3,3,3,2}$	$V_{1/6,(1/3)^{11}}^3/S_{11}$
$F_{6,2,2,1}, F_{5,2,2,2}, F_{4,4,2,1}, F_{4,3,2,2}$	$V_{0,(5/11)^{11}}^4/S_{11}$
$F_{7,2,1,1}, F_{6,2,2,1}, F_{4,4,2,1}$	not obtained from assignments or GIT
$F_{8,1,1,1}, F_{7,2,1,1}, F_{5,4,1,1}, F_{4,4,2,1}$	$V_{1/4,(1/4)^{11}}^2/S_{11}$
$F_{6,3,1,1}, F_{6,2,2,1}, F_{5,2,2,2}$	not obtained from assignments or GIT
$F_{8,1,1,1}, F_{7,2,1,1}, F_{6,3,1,1}, F_{6,2,2,1}$	$\bar{M}_{0,((1/5)^{11})}/S_{11} = (\mathbb{P}^1)^{11} // \text{SL}_2 / S_{11} = \mathbb{P}^{11} // \text{SL}_2$

TABLE 5. List of contractions of $\tilde{M}_{0,11}$ corresponding to extremal rays

Example 11.1 (Non-projective smooth assignment). Let Z be a smooth extremal assignment of order 6 whose maximal elements in the contraction indicator are

$$\{1, 2, 3, 4\}, \{1, 2, 5\}, \{3, 4, 5\}, \{2, 3, 6\}, \{1, 4, 6\}.$$

Then it is straightforward to check that the contracted F-curves by $\pi_Z : \overline{M}_{0,6} \rightarrow \overline{M}_{0,6}(Z)$ are

$$\begin{aligned} &F_{\{1\},\{2\},\{3\},\{4,5,6\}}, F_{\{1\},\{2\},\{4\},\{3,5,6\}}, F_{\{1\},\{2\},\{5\},\{3,4,6\}}, F_{\{1\},\{3\},\{4\},\{2,5,6\}}, F_{\{1\},\{4\},\{6\},\{2,3,5\}}, \\ &F_{\{2\},\{3\},\{4\},\{1,5,6\}}, F_{\{2\},\{3\},\{6\},\{1,4,5\}}, F_{\{3\},\{4\},\{5\},\{1,2,6\}}, F_{\{1\},\{2\},\{3,4\},\{5,6\}}, F_{\{1\},\{3\},\{2,4\},\{5,6\}}, \\ &F_{\{1\},\{4\},\{2,3\},\{5,6\}}, F_{\{2\},\{3\},\{1,4\},\{5,6\}}, F_{\{2\},\{4\},\{1,3\},\{5,6\}}, F_{\{3\},\{4\},\{1,2\},\{5,6\}}. \end{aligned}$$

Note that the curve cone $\text{NE}_1(\overline{M}_{0,6})$ is generated by F-curves ([KM13, Theorem 1.2]). If $\overline{M}_{0,6}(Z)$ is projective, then there is $N \in \text{Nef}(\overline{M}_{0,6})$ such that for an F-curve F , $N \cdot F = 0$ if and only if F is in the above list. By using a computer program, it can be shown that there is no such divisor N .

Example 11.2. By a similar idea, one can check that the smooth extremal assignment Z in Example 7.14 gives a non-projective birational contraction $\overline{M}_{0,7}(Z)$.

Example 11.3 (Non-projective S_n -invariant assignment). Let Z be an S_{12} -invariant extremal assignment of order 12, which corresponds to integer partitions $\{7, 3, 1, 1\}$ and $\{3, 3, 3, 3\}$. Then the contracted F-curves are exactly $F_{7,3,1,1}$ and $F_{3,3,3,3}$. The S_n -invariant F-conjecture is true up to $n \leq 24$ ([Gib09, Theorem 6.1]), so $\text{NE}_1(\overline{M}_{0,12})$ is generated by F-curves. By using a similar computation with Example 11.1, we can check that $\overline{M}_{0,12}(Z)$ is not projective.

Remark 11.4. However, by Proposition 9.9, every S_n -invariant smooth extremal assignment gives a projective birational contraction.

We finish this section with a partial positive result showing that some birational models are indeed varieties.

Proposition 11.5. *Let Z be a smooth extremal assignment. Then $\overline{M}_{0,n}(Z)$ is a proper variety.*

Proof. Since we already know that $\overline{M}_{0,n}(Z)$ is a smooth proper algebraic space, it suffices to show that it is a scheme. Let $X := (C, x_1, x_2, \dots, x_n) \in \overline{M}_{0,n}(Z)$. Since Z is smooth, C is obtained from $(C^s, x_1^s, x_2^s, \dots, x_n^s) \in \overline{M}_{0,n}$ by contracting some (not necessarily irreducible) tails. Thus if we define weight data A such that the sum over each tail is at most one, then $X \in \overline{M}_{0,A}$. Furthermore, since a deformation of X is obtained by perturbing marked points and resolving some singularities, any small deformation of X is also in $\overline{M}_{0,A}$. Therefore there is a Zariski open neighborhood U of X in $\overline{M}_{0,n}(Z)$, which is isomorphic to an open neighborhood of X in $\overline{M}_{0,A}$. Since $\overline{M}_{0,A}$ is a projective variety, U is a scheme. Therefore any point of $\overline{M}_{0,n}(Z)$ has a Zariski open neighborhood which is a scheme. This implies $\overline{M}_{0,n}(Z)$ is a scheme. \square

Remark 11.6. Therefore, by using extremal assignments, we obtain many examples of smooth proper and non-projective varieties.

We expect that this is true for any extremal assignment Z .

Conjecture 11.7. *For any extremal assignment Z , $\overline{M}_{0,n}(Z)$ is a proper variety.*

REFERENCES

- [Ber89] Claude Berge. *Hypergraphs*, volume 45 of *North-Holland Mathematical Library*. North-Holland Publishing Co., Amsterdam, 1989. Combinatorics of finite sets, Translated from the French. [2](#), [23](#)
- [BH11] Gilberto Bini and John Harer. Euler characteristics of moduli spaces of curves. *J. Eur. Math. Soc. (JEMS)*, 13(2):487–512, 2011. [4](#)
- [BM13] Jonas Bergström and Satoshi Minabe. On the cohomology of moduli spaces of (weighted) stable rational curves. *Math. Z.*, 275(3-4):1095–1108, 2013. [4](#)
- [BM14] Jonas Bergström and Satoshi Minabe. On the cohomology of the Losev-Manin moduli space. *Manuscripta Math.*, 144(1-2):241–252, 2014. [4](#)
- [Bog99] Marco Boggi. Compactifications of configurations of points on \mathbb{P}^1 and quadratic transformations of projective space. *Indag. Math. (N.S.)*, 10(2):191–202, 1999. [12](#)
- [Cey09] Özgür Ceyhan. Chow groups of the moduli spaces of weighted pointed stable curves of genus zero. *Adv. Math.*, 221(6):1964–1978, 2009. [4](#)
- [CT15] Ana-Maria Castravet and Jenia Tevelev. $\overline{M}_{0,n}$ is not a Mori dream space. *Duke Math. J.*, 164(8):1641–1667, 2015. [27](#)
- [dRJR16] Rodrigo Ferreira da Rosa, David Jensen, and Dhruv Ranganathan. Toric graph associahedra and compactifications of $M_{0,n}$. *J. Algebraic Combin.*, 43 (2016), no. 1, 139–151. [3](#), [26](#)
- [FN72] Akira Fujiki and Shigeo Nakano. Supplement to “On the inverse of monoidal transformation”. *Publ. Res. Inst. Math. Sci.*, 7:637–644, 1971/72. [24](#)
- [Ful93] William Fulton. *Introduction to toric varieties*, volume 131 of *Annals of Mathematics Studies*. Princeton University Press, Princeton, NJ, 1993. The William H. Roever Lectures in Geometry. [26](#)
- [Gib09] Angela Gibney. Numerical criteria for divisors on \overline{M}_g to be ample. *Compos. Math.*, 145(5):1227–1248, 2009. [35](#)
- [GJM13] Noah Giansiracusa, David Jensen, and Han-Bom Moon. GIT compactifications of $\overline{M}_{0,n}$ and flips. *Adv. Math.*, 248:242–278, 2013. [3](#), [13](#), [33](#)
- [GJMS13] Angela Gibney, David Jensen, Han-Bom Moon, and David Swinarski. Veronese quotient models of $\overline{M}_{0,n}$ and conormal blocks. *Michigan Math. J.*, 62(4):721–751, 2013. [3](#), [33](#)
- [Has03] Brendan Hassett. Moduli spaces of weighted pointed stable curves. *Adv. Math.*, 173(2):316–352, 2003. [3](#), [12](#), [24](#), [26](#)
- [Has05] Brendan Hassett. Classical and minimal models of the moduli space of curves of genus two. In *Geometric methods in algebra and number theory*, volume 235 of *Progr. Math.*, pages 169–192. Birkhäuser Boston, Boston, MA, 2005. [31](#)
- [Kap93a] M. M. Kapranov. Chow quotients of Grassmannians. I. In *I. M. Gelfand Seminar*, volume 16 of *Adv. Soviet Math.*, pages 29–110. Amer. Math. Soc., Providence, RI, 1993. [1](#)
- [Kap93b] M. M. Kapranov. Veronese curves and Grothendieck-Knudsen moduli space $\overline{M}_{0,n}$. *J. Algebraic Geom.*, 2(2):239–262, 1993. [1](#)
- [KM13] Seán Keel and James McKernan. Contractible extremal rays on $\overline{M}_{0,n}$. In *Handbook of moduli. Vol. II*, volume 25 of *Adv. Lect. Math. (ALM)*, pages 115–130. Int. Press, Somerville, MA, 2013. [6](#), [35](#)
- [LM00] A. Losev and Y. Manin. New moduli spaces of pointed curves and pencils of flat connections. *Michigan Math. J.*, 48:443–472, 2000. Dedicated to William Fulton on the occasion of his 60th birthday. [2](#), [25](#)
- [Man95] Yu. I. Manin. Generating functions in algebraic geometry and sums over trees. In *The moduli space of curves (Texel Island, 1994)*, volume 129 of *Progr. Math.*, pages 401–417. Birkhäuser Boston, Boston, MA, 1995. [4](#)
- [Moo11] Han-Bom Moon. *Birational geometry of moduli spaces of curves of genus zero*. PhD thesis, Seoul National University, 2011. [4](#)
- [Moo15] Han-Bom Moon. Mori’s program for $\overline{M}_{0,6}$ with symmetric divisors. *Math. Nachr.*, 288(7):824–836, 2015. [31](#)
- [S⁺] W. A. Stein et al. *Sage*. The Sage Development Team, Sage Mathematics Software (Version 6.5). [3](#)
- [Sek96] J. Sekiguchi. Cross ratio varieties for root systems of type A and the Terada model. *J. Math. Sci. Univ. Tokyo*, 3(1):181–197, 1996. [1](#)
- [Smy13] David Ishii Smyth. Towards a classification of modular compactifications of $M_{g,n}$. *Invent. Math.*, 192(2):459–503, 2013. [1](#), [8](#), [9](#), [12](#)